

BF07K

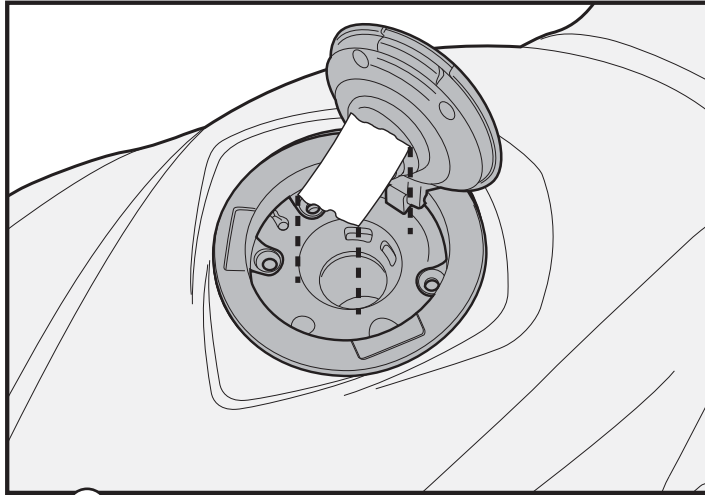
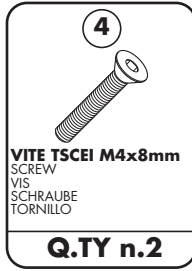
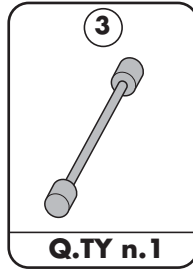
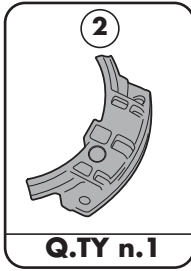
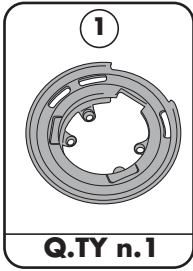

PRIMA DI PROCEDERE APPLICARE DELLO SCOTCH SUL FORO DEL SERBATOIO PER EVITARE DI FARVI CADERE ACCIDENTALMENTE DELLE VITI.

BEFORE STARTING, APPLY SOME ADHESIVE TAPE TO CLOSE THE TANK HOLE TO PREVENT SCREWS FROM FALLING INSIDE IT

AVANT DE COMMENCER, APPLIQUEZ UN PEU DE RUBAN SUR LE RESERVOIR POUR EVITER LA PERTE DE VIS

BEVOR SIE BEGINNEN, GELTEN ETWAS KLEBEBAND AUF DEM TANK, UM DEN VERLUST VON SCHRAUBEN VERMEIDEN

ANTES DE COMENZAR, APLIQUE UN POCO DE CINTA EN EL TANQUE PARA EVITAR LA PÉRDIDA DE LOS TORNILLOS

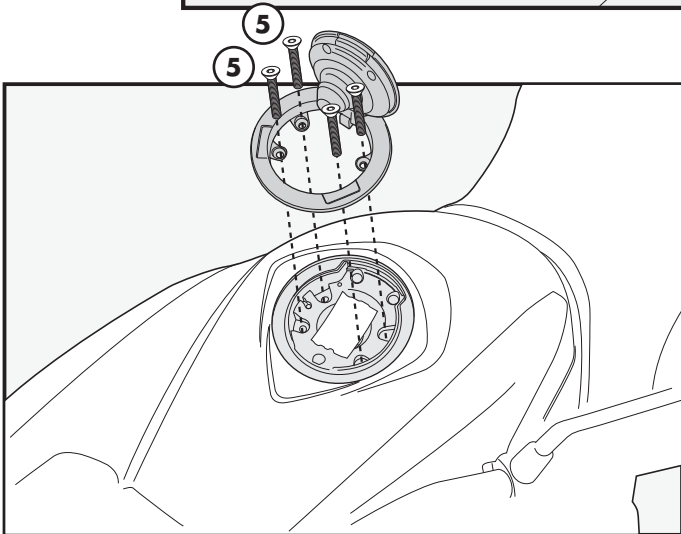

Svitare e smontare il tappo del serbatoio dalla ghiera originale
Unscrew and remove the original cap of the tank
Dévisser et enlever le bouchon d'origine du réservoir
Lösen und entfernen Sie die ursprüngliche Deckel des Tanks
Destornille y quite la tapa original del depósito

Sostituire	Con	
Replace	With	
Remplacer	Avec	
Ersetzen	Mit	
Reemplazar	Con	

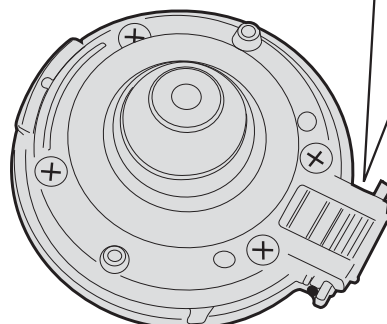
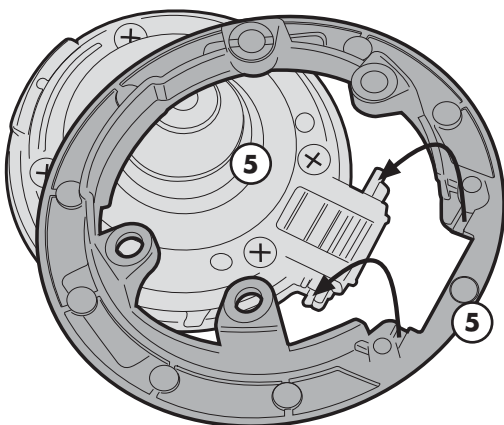

BF07K

