

ES1111 - ES1111K

ESTENSIONE CAVALLETTO LATERALE - SIDE STAND EXTENSION - FUSSVERBREITERUNGEN FÜR SEITENSTÄNDER
ZIJSTANDAARD EXTENSIE - EXTENSIÓN DEL CABALLETE LATERAL - EXTENSÃO DO CAVALETE LATERAL

N°	Descrizione/Description	Caratteristiche/Features	Codice/Code	Quantità/Quantity
1	Supporto - Support - Support Halteung - Soporte - Apoio	Alluminio	GL2788	1
2	Supporto - Support - Support Halteung - Soporte - Apoio	INOX316	GL2789	1
3	Supporto - Support - Support Halteung - Soporte - Apoio	INOX316	GL2790	1
4	Supporto - Support - Support Halteung - Soporte - Apoio	INOX316	GL2791	2
5	Vite - Screw Vis - Schraube Tornillo - Parafuso	M5x8	-	4

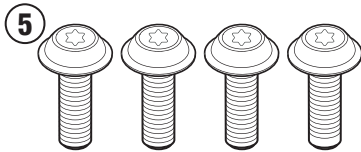
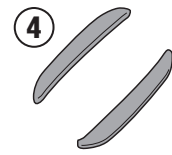
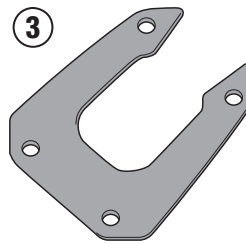
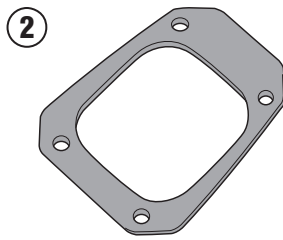
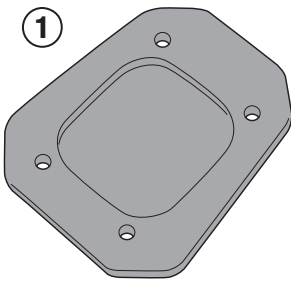

ITA - Mettere del liquido frenafilletti sullo stelo delle viti prima di avitarle.
 ENG - Put threadlocking fluid on the shaft of the screws before tightening them.
 FRA - Mettez du liquide frein-filet sur l'axe des vis avant de les serrer.
 ESP - Aplicar líquido fijador de roscas en el eje de los tornillos antes de apretarlos.
 DEU - Tragen Sie vor dem Eindrehen der Schrauben Gewindesicherungsflüssigkeit auf den Schaft der Schrauben auf.
 POR - Coloque o líquido de travamento de rosca no eixo dos parafusos antes de apertá-los.

IT_ Estensione cavalletto laterale progettata in modo tale da non essere il primo elemento a toccare terra con il veicolo in configurazione originale. Rilevamenti effettuati con veicolo aggiornato al 05/02/2025

EN_ Side stand extension designed so that it is not the first element to touch the ground with the vehicle in its original configuration. Analysis conducted with updated vehicle at 05/02/2025.

DE_ Fussverbreiterungen für seitenständer, der so konstruiert ist, dass er nicht als erstes Element den Boden berührt, wenn das Fahrzeug in Originalkonfiguration ist. Messungen mit zum 05/02/2025 aktualisiertem Fahrzeug durchgeführt

FR_ Extensión del caballete lateral conçu de manière à ne pas être le premier élément à toucher le sol avec le véhicule dans sa configuration d'origine. Enquêtes réalisées avec véhicule mis à jour au 05/02/2025

ES_ Extensión del caballete lateral diseñado de tal manera que no sea el primer elemento en tocar tierra con el vehículo en la configuración original. Mediciones efectuadas con el vehículo actualizado al 05/02/2025

PT_ Extensão do cavalete lateral elaborado para não ser o primeiro elemento a tocar o piso com o veículo na configuração original. Vistorias realizadas com veículo atualizado em 05/02/2025



ISTRUZIONI DI MONTAGGIO - MOUNTING INSTRUCTIONS
 INSTRUCTIONS DE MONTAGE - BAUANLEITUNG
 INSTRUCCIONES DE MONTAJE - INSTRUÇÕES DE MONTAGEM

ES1111 - ES1111K

ESTENSIONE CAVALLETTO LATERALE - SIDE STAND EXTENSION - FUSSVERBREITERUNGEN FÜR SEITENSTÄNDER
ZUGSTAND EXTENSIE - EXTENSIÓN DEL CABALLETE LATERAL - EXTENSÃO DO CAVALETE LATERAL

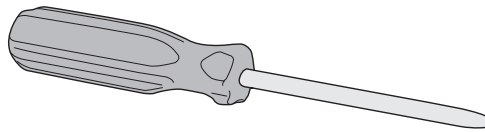
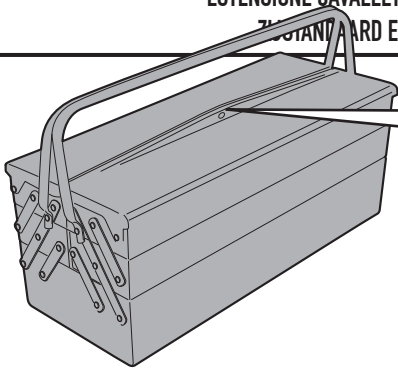

T 25

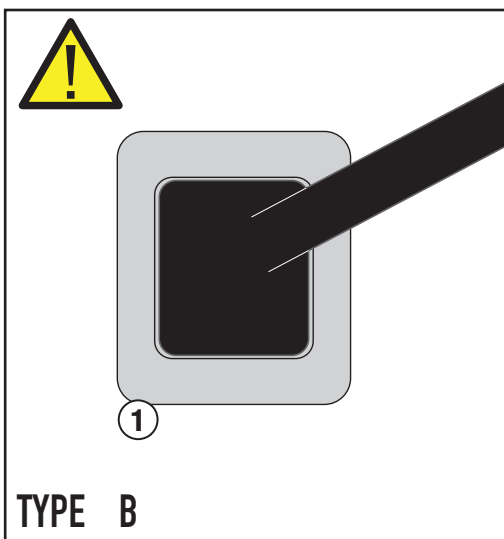
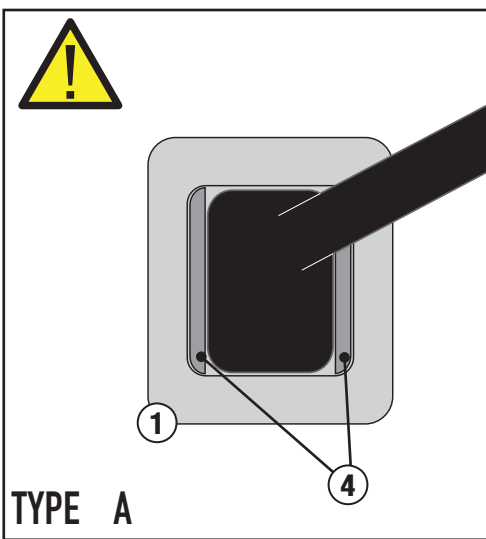
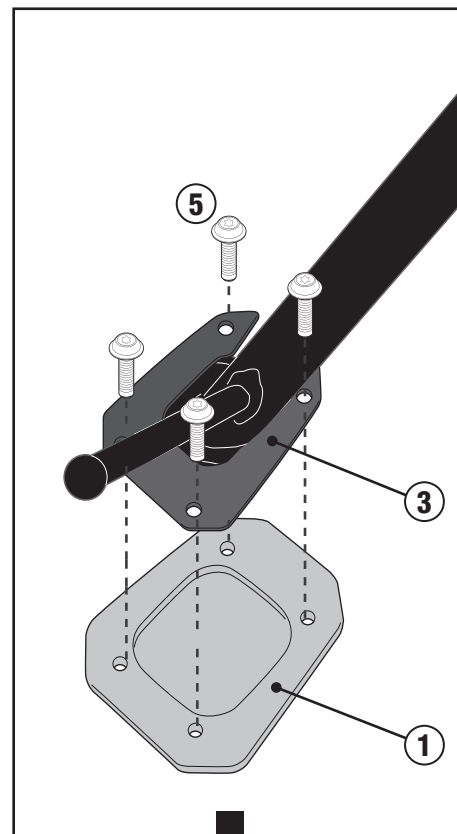
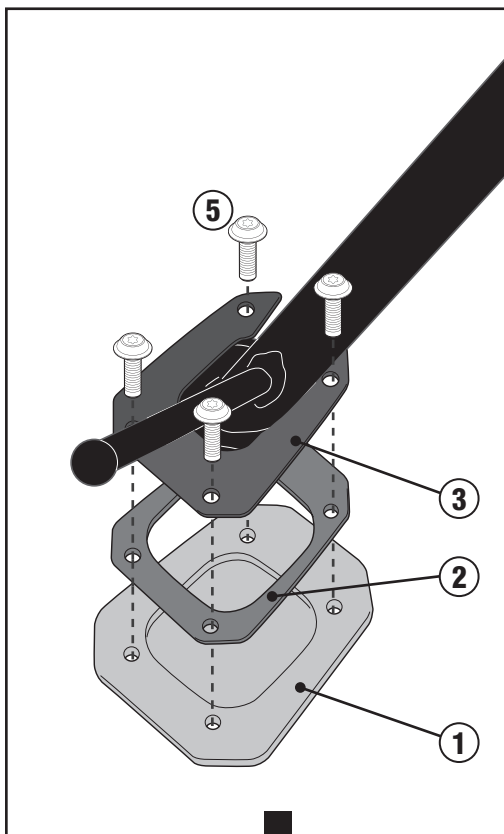
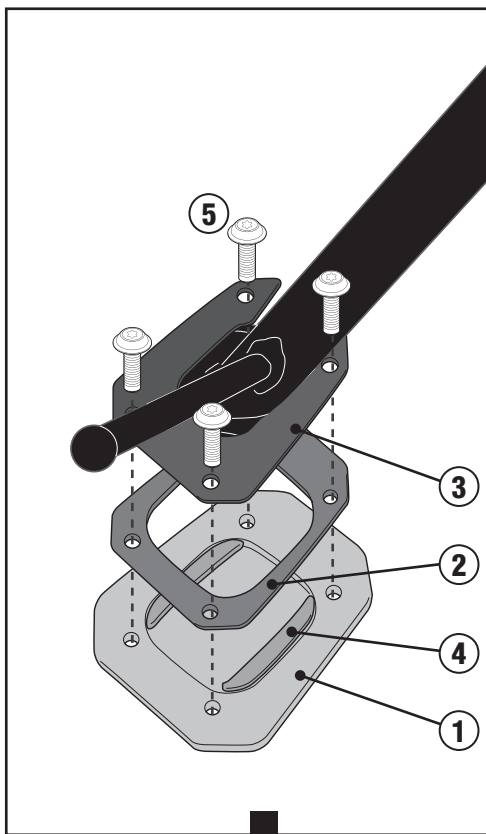

**ONLY FOR
TRANSALP 750 - 2026**