

MONORACK SPECIFICO - SPECIFIC MONORACK
 MONORACK SPECIFIQUE - SPEZIFISCHES MONORACK - MONORACK ESPECÍFICO

HONDA CBR1000F '89/'00

ISTRUZIONI DI MONTAGGIO - MOUNTING INSTRUCTIONS
 INSTRUCTIONS DE MONTAGE - BAUANLEITUNG - INSTRUCCIONES DE MONTAJE

HONDA CBR 1000 F '89-90-91-92 (SUPER SPORT)

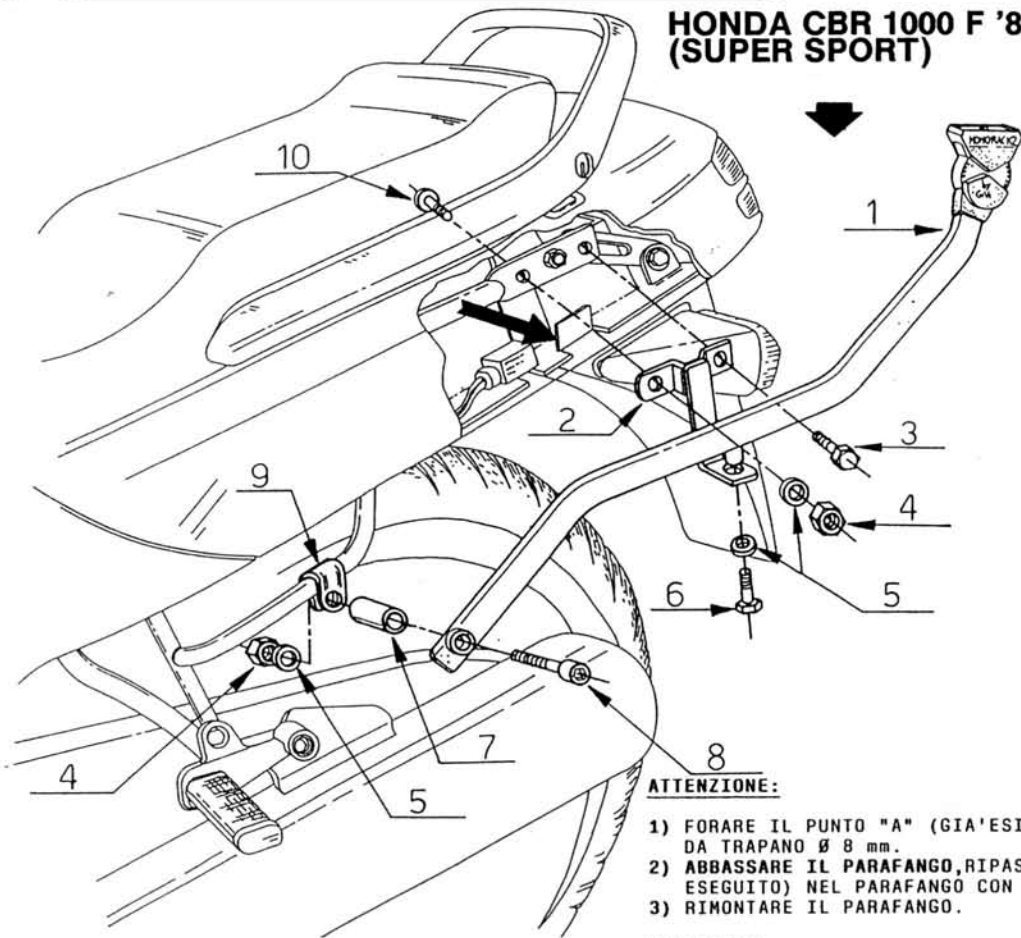

ATTENZIONE:

- 1) FORARE IL PUNTO "A" (GIÀ ESISTENTE) CON PUNTA DA TRAPANO Ø 8 mm.
- 2) ABBASSARE IL PARAFANGO, RIPASSARE IL FORO (APPENA ESEGUITO) NEL PARAFANGO CON PUNTA Ø 12 mm.
- 3) RIMONTARE IL PARAFANGO.

ATTENTION:

- 1) DRILL POINT "A" (ALREADY EXISTING) WITH Ø 8 mm.
- 2) LOWER THE MUDGUARD, DRILL AGAIN THE HOLE (JUST MADE) IN THE MUDGUARD WITH Ø 12 mm.
- 3) REMOUNT THE MUDGUARD.

ATTENTION:

- 1) PERCER LE POINT "A" (DEJA EXISTANT) AVEC POINT DE PERCEUSE Ø 8 mm.
- 2) BAISSER LE BARA-BOUE REPERCER LE POINT (JUSTE EXECUTE) DANS LE PARA-BOUE AVEC DE PERCEUSE Ø 12 mm.
- 3) REMONTER LE PARA-BOUE.

N°	DESCRIZIONE DEL KIT (KIT DESCRIPTION) (DESCRIPTION DU KIT)	QUANTITA' (QUANTITY) (QUANTITE)		
1	MONORACK	2	8	VITE TCE1 M 8 X 60 (SCREW M 8 X 60) (VIS M 8 X 60°6 PANS CREUX)
2	SUPPORTO SPECIFICO (SPECIFIC SUPPORT) (SUPPORT SPECIFIQUE)	2	9	FASCETTA Ø 16 (CLAMP Ø 16) (CRAMPON Ø 16)
3	VITE ORIGINALE (ORIGINAL SCREW) (VIS D'ORIGINE)	-	10	VITE TPSCET M 8 X 20 (SCREW M 8 X 20) (VIS M 8 X 20)
4	DADO M 8 (NUT M 8) (ECROU M 8)	4	11	VITE TE M 8 X 25 (SCREW M 8 X 25) (VIS M 8 X 25)
5	RONDELLA Ø 8 (WASHER Ø 8) (RONDELLE Ø 8)	8	12	DISTANZIALE Ø 14 X 6 R1B.F.Ø 6 (COLLAR DISTANCE Ø 14 X 5) (COLLIER DE SEPARATION Ø 14 X 5)
6	VITE TE M 8 X 16 (SCREW M 8 X 16) (VIS M 8 X 16)	2	13	VITE TE M 6 X 20 (SCREW M 6 X 20) (VIS M 6 X 20)
7	DISTANZIALE Ø 20 X 30 (COLLAR DISTANCE Ø 20 X 30) (COLLIER DE SEPARATION Ø 20 X 30)	2	14	DISTANZIALE Ø 16 X 9 R1B (COLLAR DISTANCE Ø 16 X 9) (COLLIER DE SEPARATION Ø 16 X 9)

HONDA CBR 1000 F 1993

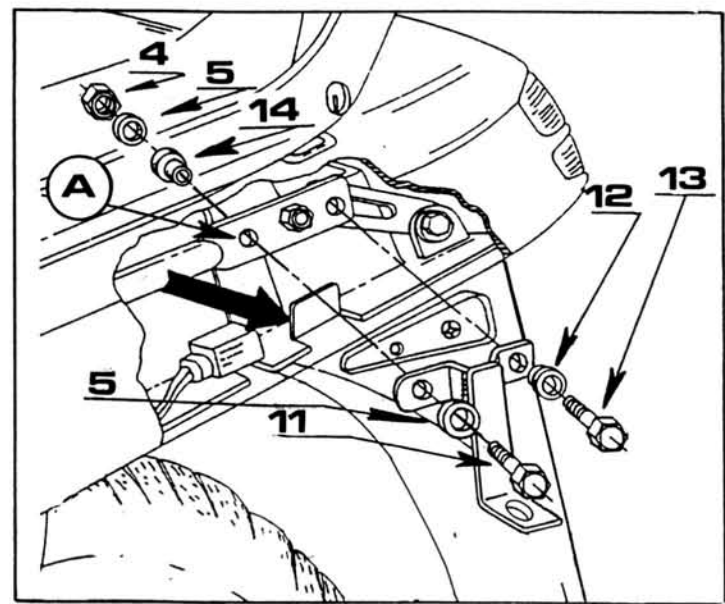

TOGLIERE IL LEMBO DI PLASTICA COME DA DISEGNO (CUT THE PLASTIC STRIP AS IN PICTURE) (ENLEVER LE BORD EN PLASTIQUE COMME DANS LE DESSIN)

