

# FB1211 – KFB1211

## Traversino - Fairing upper bracket - Support gps pour carenage - Barra Halierung zur montage am windschild - Suporte

N°	Descrizione/Description	Caratteristiche/Features	Codice/Code	Quantità/Quantity
1	Supporto laterale - Lower frame Support latéral - Soporte lateral Untere Halierung - Suporte lateral	-	GL6077DXV GL6077SXV	2 (Right/Left)
2	Supporto superiore - Support higher - Support supérieur Halierung höher - Soporte superior - Apoio superior	-	V975	1
3	Vite - Screw - Vis - Schraube Tornillo - Parafuso	TBEIFF 6X12	616TBEIFF	2
4	Rondella spaccata - Split washer - Scheibe - Rondelle fendue Arandela seccionada - Arruela quebrada	Foro Ø6mm	Z1063	2
5	Vite - Screw - Vis - Schraube Tornillo - Parafuso	TBEIFN 6X16	616TBEIFN	4
6	Rondella In Nylon - Nylon Washer Rondelle Original En Nylon - Nylonscheibe Arandela De Nylon - Arruela De Nylon	Foro Ø6mm Esterno Ø13mm	Z1979	4
7	Distanziale - Spacer - Entretoise - Distanzstueck Distanciador - Españador	Ø9x5 Foro 6,5mm	C9L5F6,5T	4
8	Rondella In Nylon - Nylon Washer Rondelle Original En Nylon - Nylonscheibe Arandela De Nylon - Arruela De Nylon	Ø5,5X13X0,5mm	Z9683	4
9	Mousse Protettiva - Protective Rubber Pads Mousse De Protection - Schutzgummi Espuma Adhesiva Protectora	MOUSSE	Z298	4
10	Componenti Originali - Original Parts Parties Originales - Original Bauteile Componentes Originales - Componentes Originais	-	-	-

# FB1211 - KFB1211

Traversino - Fairing upper bracket - Support gps pour carenage - Barra  
Halterung zur montage am windschild - Suporte

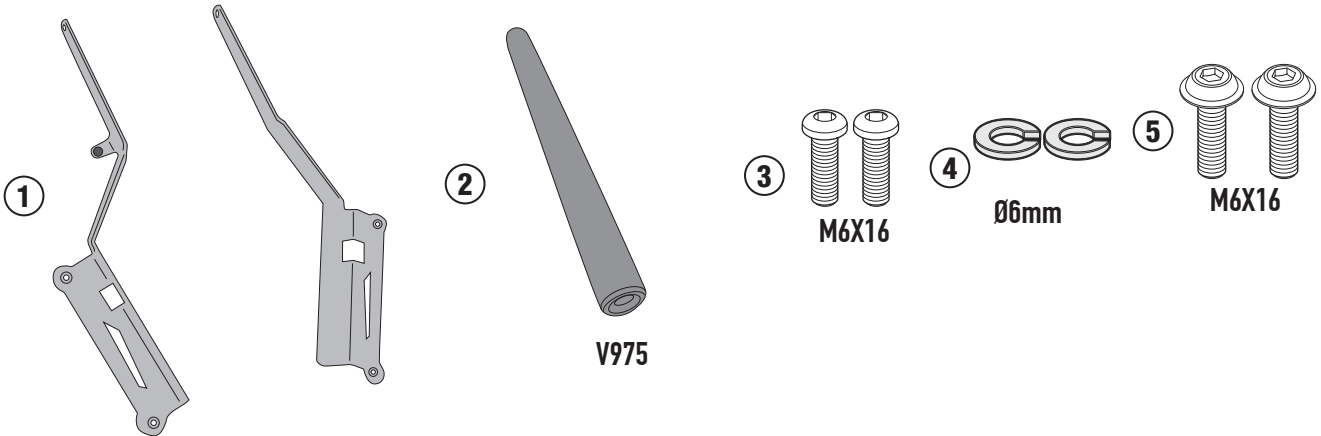

GL6077DXV  
GL6077SXV

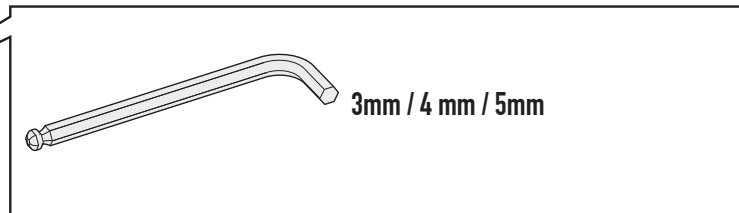
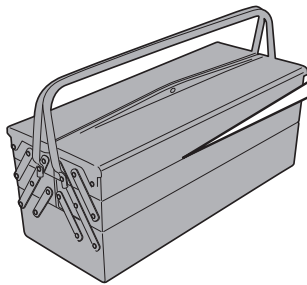
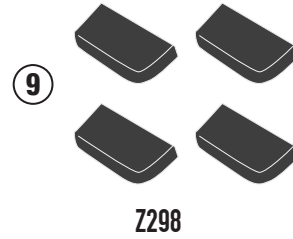
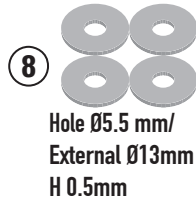
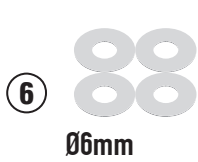

# FB1211 - KFB1211

Traversino - Fairing upper bracket - Support gps pour carenage - Barra

Halterung zur montage am windschild - Suporte

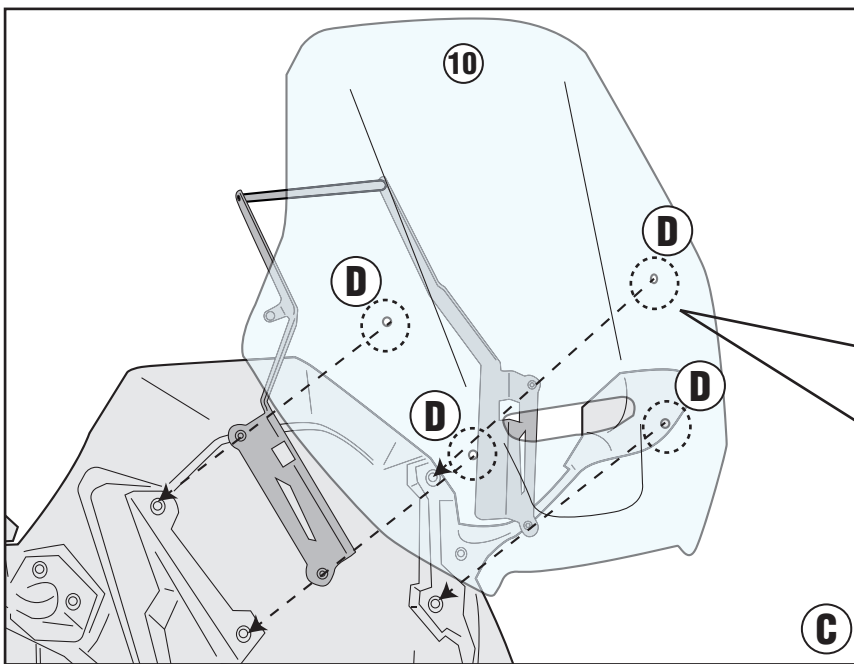
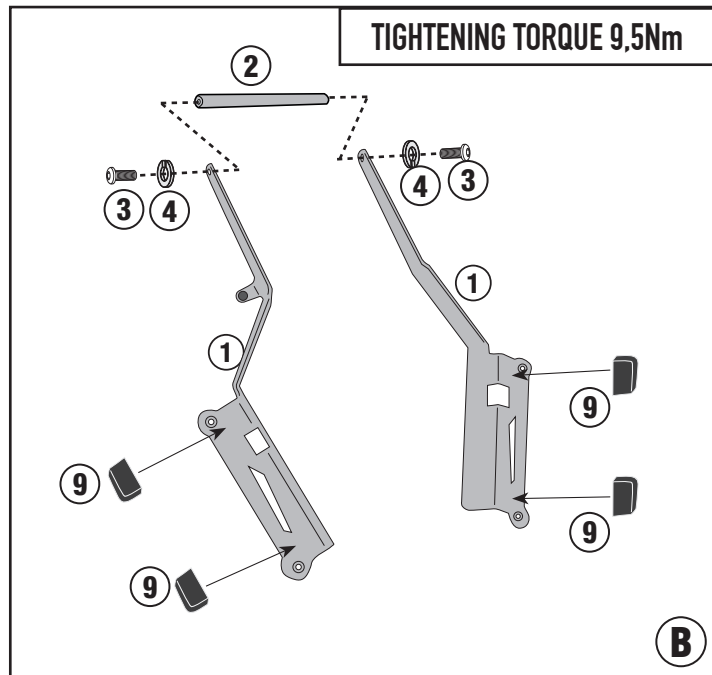
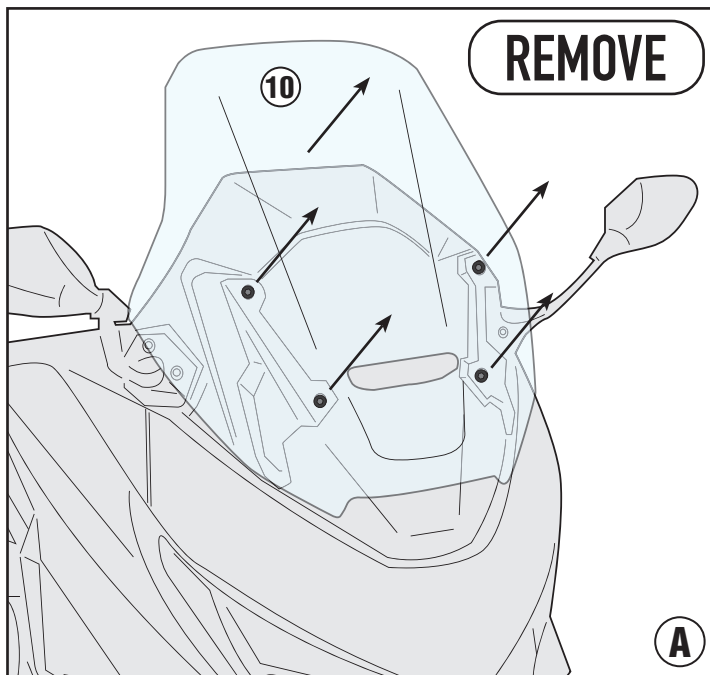

**ATTENTION**  
TO USE THE FB1211 WITH D1211KIT, THE FB1211 MUST BE FITTED BEFORE THE D1211KIT USING THE SCREW AND WASHER PRESENT INSIDE THE KIT D1211KIT (N° 3 AND 4)

