

# PL03118MK - KL03118MK

PORTAVALIGIE LATERALE SPECIFICO - SPECIFIC TUBULAR SIDE-CASE HOLDER - PORTE-VALISES LATÉRAUX SPÉCIFIQUE  
SPEZIFISCHES STAHLROHR-SEITENTRAEGER - PORTA MALETAS LATERALES ESPECÍFICO - SUPORTE DE MALAS ESPECÍFICO

## SUZUKI V-STROM 1050/ V-STROM 1050XT (2020-2023)/ V-STROM 1050DE (2023)

N°	Descrizione/Description	Caratteristiche/Features	Codice/Code	Quantità/quantity
1	Telaio laterale - Side frame - Châssis latéral Soporte lateral - Seitenrahmen - Suporte lateral	-	PL03118DXV PL03118SXV	2 (Right: Left)
2	Ponte - Bridge - Pont Brücke - Puente - Ponte	-	GL4414V	1
3	Supporto inferiore - Lower support - Support inférieur Soporte inferior - Untere Halterung - Suporte inferior	-	GL4410DXV GL4410SXV	2 (Right ; Left)
4	Vite - Screw - Vis - Schraube Tornillo - Parafuso	TCE M6x60	660TCE	2
5	Vite - Screw - Vis - Schraube Tornillo - Parafuso	TCE M6x80	680TCE	2
6	Vite - Screw - Vis - Schraube Tornillo - Parafuso	TBEI M8x25	825TBEI	6
7	Vite - Screw - Vis - Schraube Tornillo - Parafuso	TBEI M8x20	820TBEI	2
8	Boccola - Mounting bush Entretoise de montage - Cilindro de fi jación Montagehülse - Bucha de fi xação	-	Z4039	4
9	Distanziale - Spacer Entretoise - Distanzstueck Distanciador - Espaçador	D.18X25 RIB.8,4mm	V1041	2
10	Rondella - Washer Rondelle - Scheibe Arandela - Arruela	Foro Ø6mm Esterno Ø18mm Sp.1,5mm	618RON	6
11	Rondella - Washer Rondelle - Scheibe Arandela - Arruela	Foro Ø8mm Esterno Ø20mm Sp.2mm	820RON	8
12	Distanziale - Spacer - Entretoise Distanzstueck - Distanciador - Espaçador	Ø10x4 Foro 6mm	C10L4F6T	4
13	Distanziale - Spacer - Entretoise Distanzstueck - Distanciador - Espaçador	Ø8x10 Foro 6,4mm	C8L10F6,4T	2
14	Dado - Bolt - Ecrou Mutter - Tuerca - Porca	Dado Autobloccante Flangiato M8 (H.9,5mm)	8DADIFN	8
15	Dado - Bolt - Ecrou Mutter - Tuerca - Porca	Dado Autobloccante Flangiato Alto M6 (H.9mm)	6DADIAFLN	2
16	Coprivite - Screw Cap Cache Vis - Stopsschraube Tapa Tornillo - Capa do Parafuso	-	13COP	8
17	Coprivite - Screw Cap Cache Vis - Stopsschraube Tapa Tornillo - Capa do Parafuso	-	10COP	2
18	Componenti Originali - Original Parts Parties Originales - Original Bauteile Componentes Originales - Componentes Originais	-	-	-
19	Particolari Inclusi nel 06RKIT Components Included In The 06RKIT Pièces Incluses Dans 06RKIT Die Einzelnen Teile Sind Bei 06RKIT Despieces Incluidos 06RKIT Componentes incluidos na 06RKIT	-	-	-

# PL03118MK - KL03118MK

PORTAVALIGIE LATERALE SPECIFICO - SPECIFIC TUBULAR SIDE-CASE HOLDER - PORTE-VALISES LATÉRAUX SPÉCIFIQUE  
 SPEZIFISCHES STAHLROHR-SEITENTRAEGER - PORTA MALETAS LATERALES ESPECÍFICO - SUPORTE DE MALAS ESPECÍFICO

## SUZUKI V-STROM 1050/ V-STROM 1050XT (2020-2023)/ V-STROM 1050DE (2023)

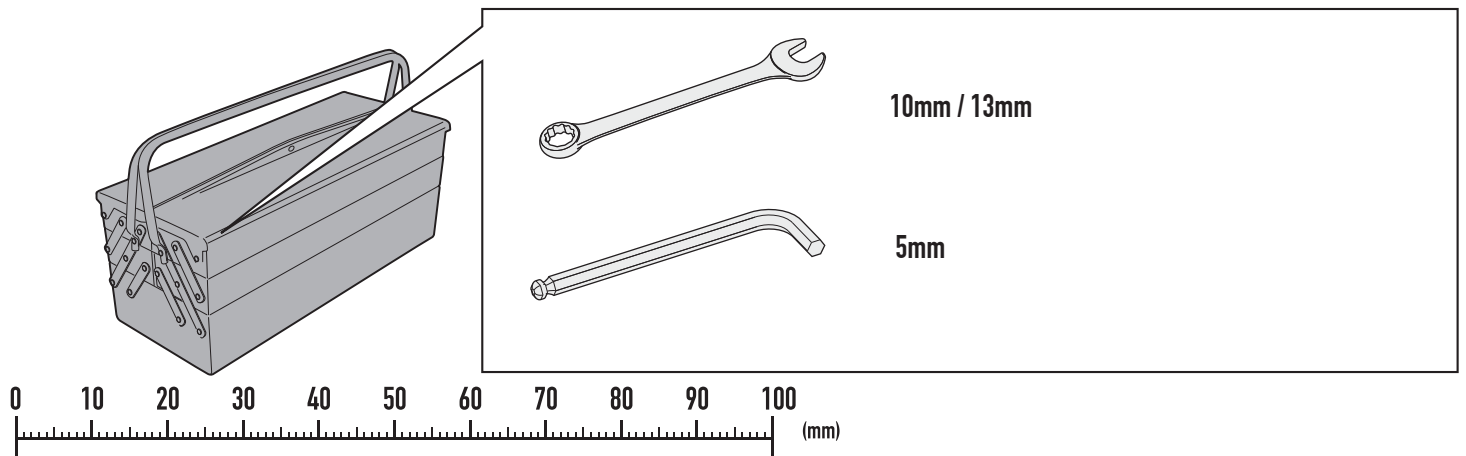
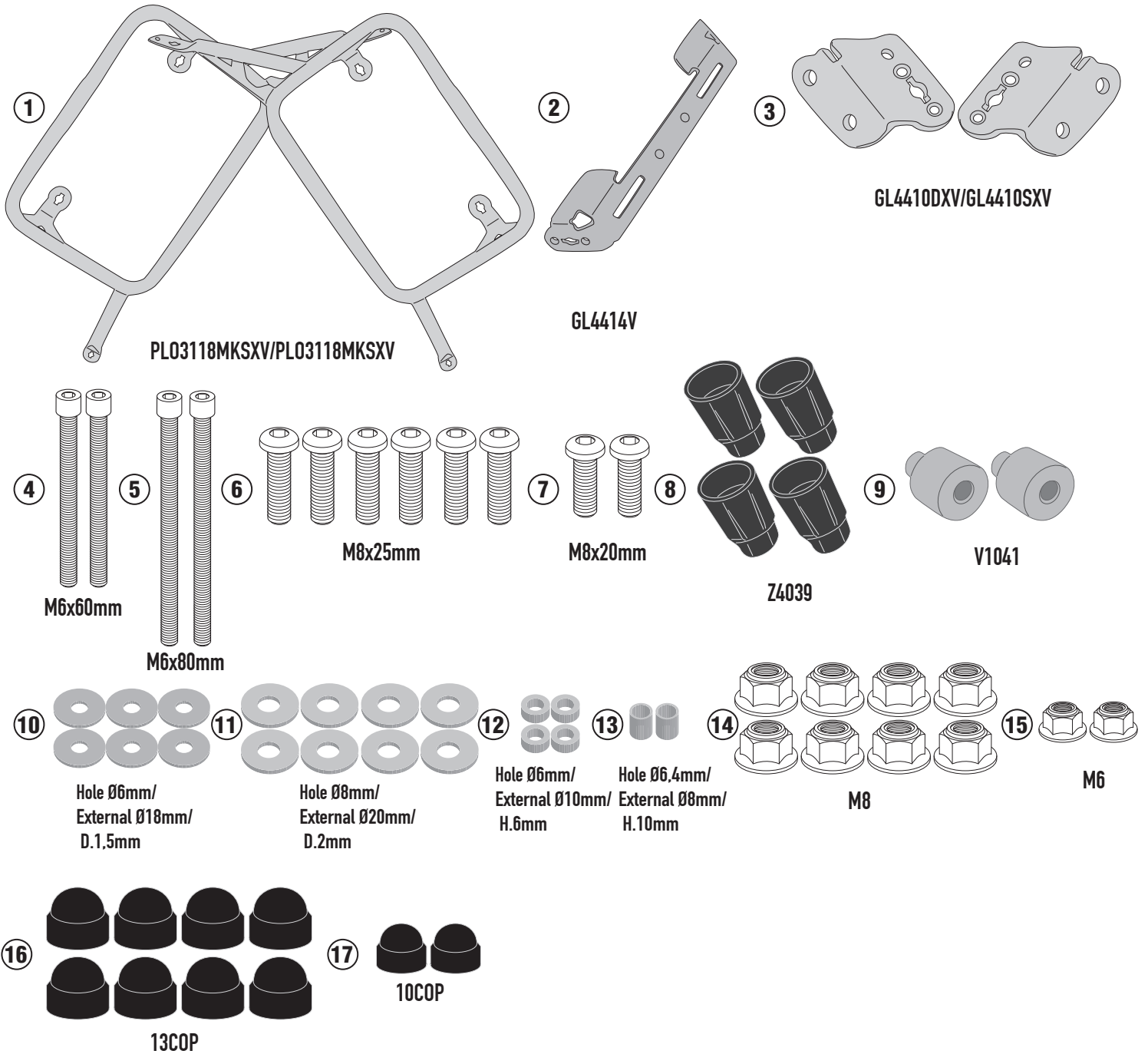

ISTRUZIONI DI MONTAGGIO - MOUNTING INSTRUCTIONS  
 INSTRUCTIONS DE MONTAGE - BAUANLEITUNG  
 INSTRUCCIONES DE MONTAJE - INSTRUÇÕES DE MONTAGEM

# PL03118MK - KL03118MK

PORTAVALIGIE LATERALE SPECIFICO - SPECIFIC TUBULAR SIDE-CASE HOLDER - PORTE-VALISES LATÉRAUX SPÉCIFIQUE  
SPEZIFISCHES STAHLROHR-SEITENTRAEGER - PORTA MALETAS LATERALES ESPECÍFICO - SUPORTE DE MALAS ESPECÍFICO

SUZUKI V-STROM 1050/ V-STROM 1050XT (2020-2023)/ V-STROM 1050DE (2023)

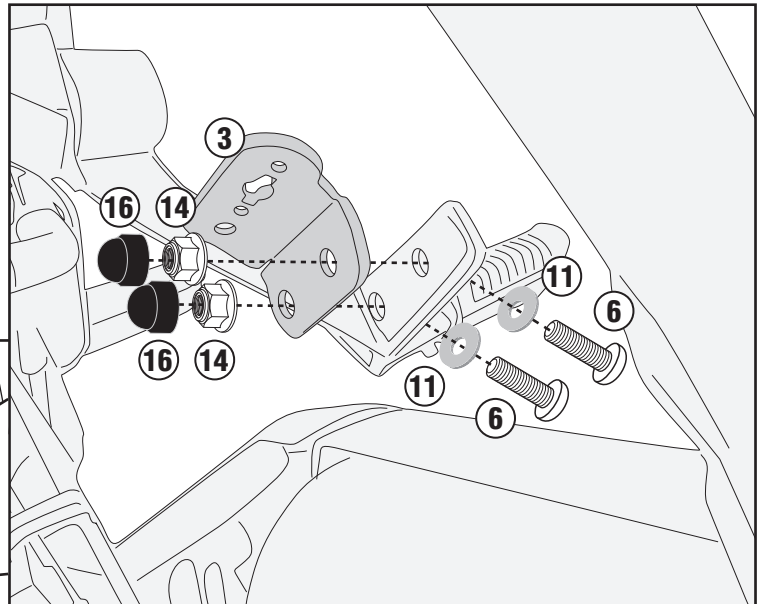
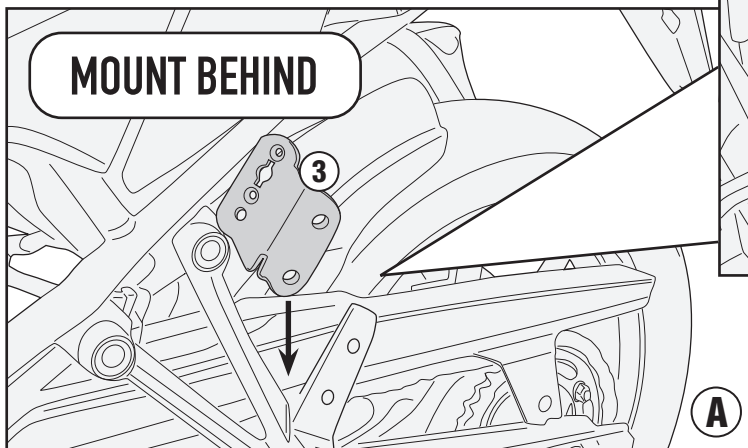
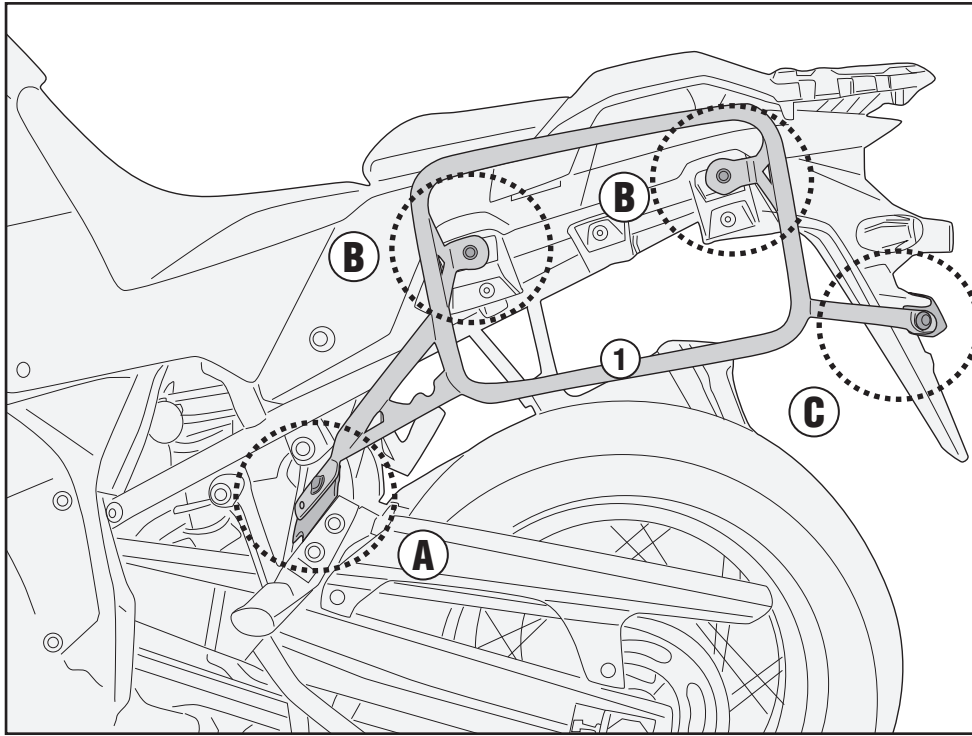

# PL03118MK - KL03118MK

PORTAVALIGIE LATERALE SPECIFICO - SPECIFIC TUBULAR SIDE-CASE HOLDER - PORTE-VALISES LATÉRAUX SPÉCIFIQUE  
SPEZIFISCHES STAHLROHR-SEITENTRAEGER - PORTA MALETAS LATERALES ESPECÍFICO - SUPORTE DE MALAS ESPECÍFICO

SUZUKI V-STROM 1050/ V-STROM 1050XT (2020-2023)/ V-STROM 1050DE (2023)

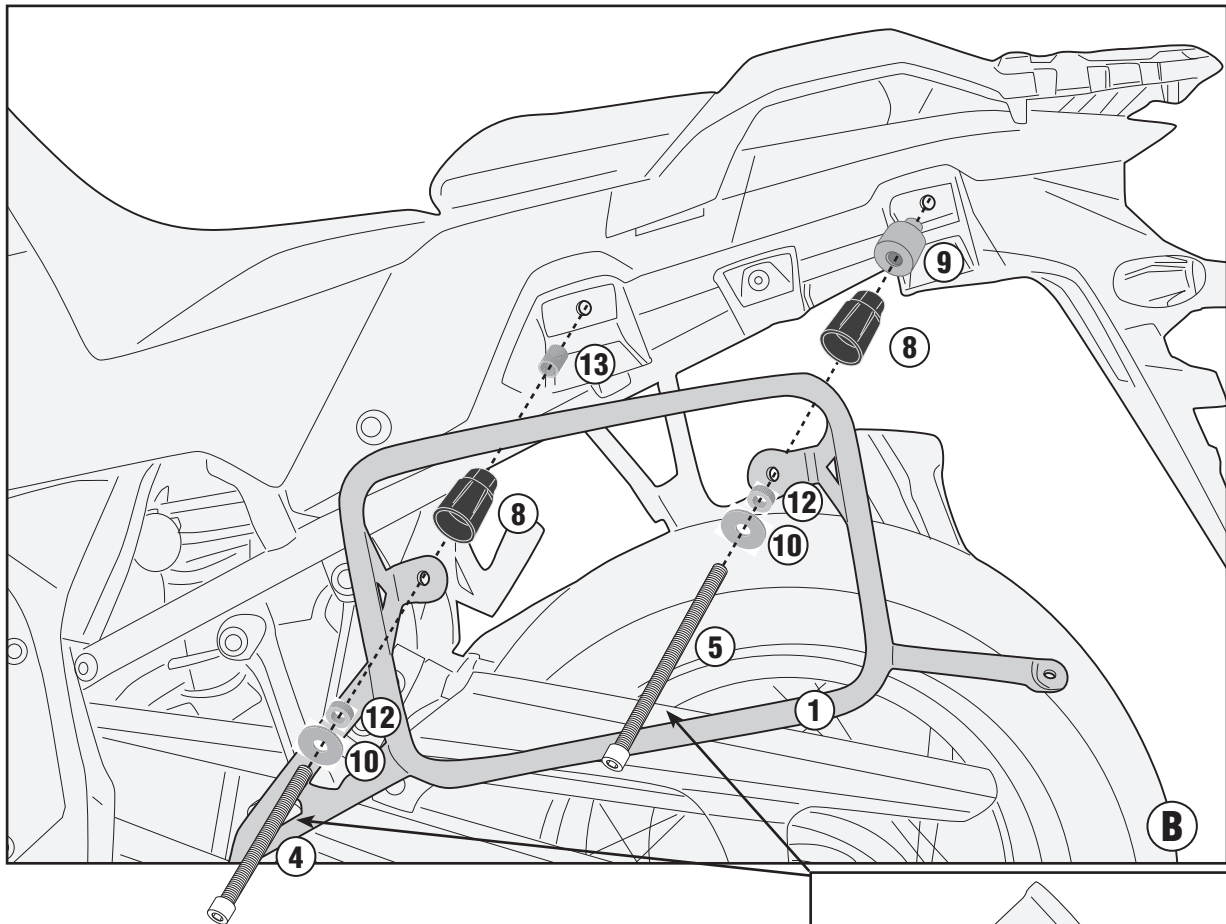
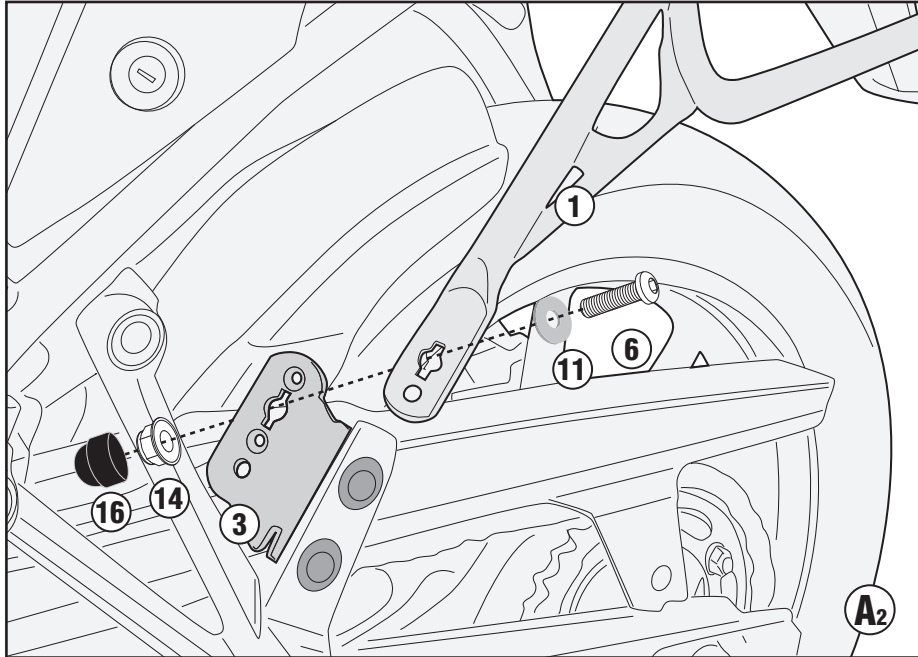

ISTRUZIONI DI MONTAGGIO - MOUNTING INSTRUCTIONS  
INSTRUCTIONS DE MONTAGE - BAUANLEITUNG  
INSTRUCCIONES DE MONTAJE - INSTRUÇÕES DE MONTAGEM

# PL03118MK - KL03118MK

PORTAVALIGIE LATERALE SPECIFICO - SPECIFIC TUBULAR SIDE-CASE HOLDER - PORTE-VALISES LATÉRAUX SPÉCIFIQUE  
SPEZIFISCHES STAHLROHR-SEITENTRAEGER - PORTA MALETAS LATERALES ESPECÍFICO - SUPORTE DE MALAS ESPECÍFICO

## SUZUKI V-STROM 1050/ V-STROM 1050XT (2020-2023)/ V-STROM 1050DE (2023)

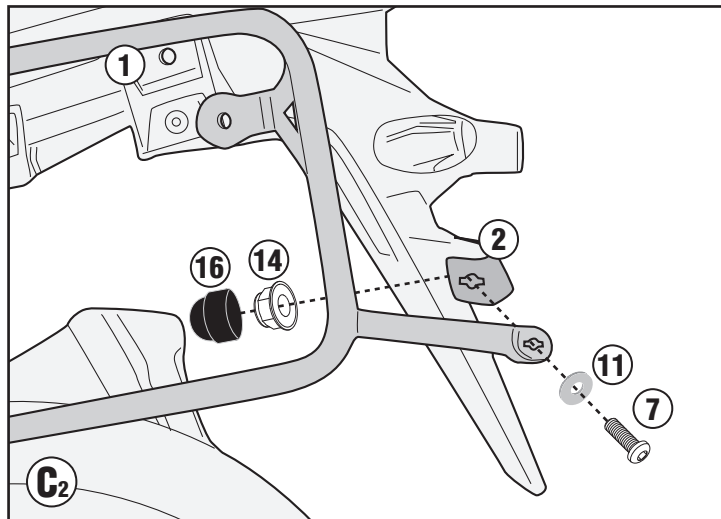
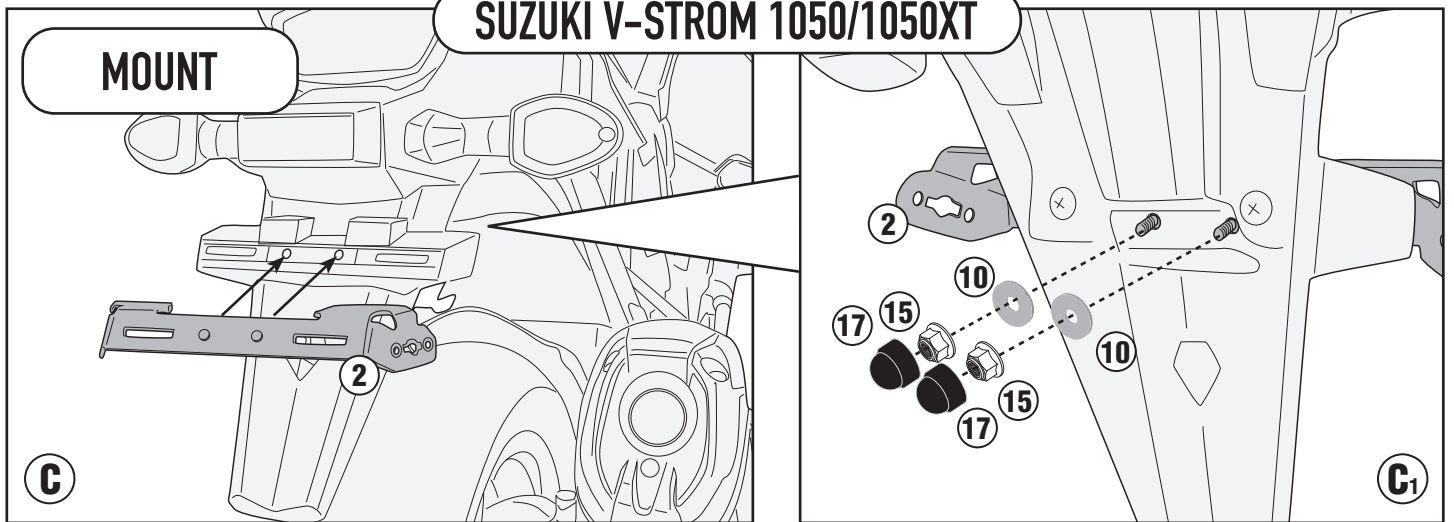

## SUZUKI V-STROM 1050DE

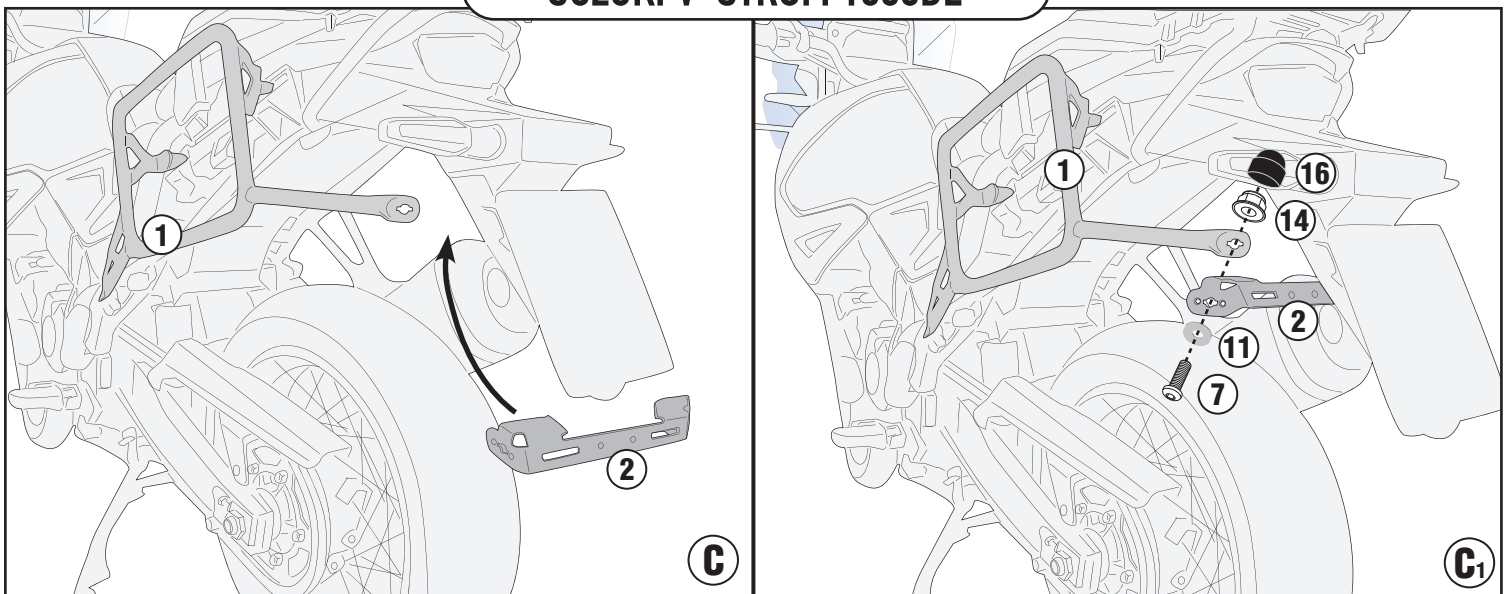

# PL03118MK - KL03118MK

PORTAVALIGIE LATERALE SPECIFICO - SPECIFIC TUBULAR SIDE-CASE HOLDER - PORTE-VALISES LATÉRAUX SPÉCIFIQUE  
SPEZIFISCHES STAHLROHR-SEITENTRÄGER - PORTA MALETAS LATERALES ESPECÍFICO - SUPORTE DE MALAS ESPECÍFICO

## SUZUKI V-STROM 1050/ V-STROM 1050XT (2020-2023)/ V-STROM 1050DE (2023)

- TRASFORMAZIONE IN PORTAVALIGIE LATERALI RAPID FITTING, AGGIUNDO IL KIT 06RKIT (DA ACQUISTARE SEPARATAMENTE)
- TRANSFORMATION INTO A RAPID FITTING SIDE-CASE HOLDER, BY ADDING THE 06RKIT KIT (TO BE PURCHASED SEPARATELY)
- VERARBEITUNG ZU EINEM SCHNELL MONTIERBAREN SEITENTRÄGER UNTER HINZUFÜGUNG DES 06RKIT-KITS (SEPARAT ZU ERWERBEN)
- TRANSFORMABLE EN KIT DE FIXATION LATÉRAL RAPIDE, EN AJOUTANT LE KIT 06RKIT (À ACHETER SÉPARÉMENT)
- SE TRANSFORMA EN UN PORTAMALETAS LATERAL DE AJUSTE RÁPIDO, AÑADIENDO EL KIT 06RKIT (SE COMPRA POR SEPARADO)
- CONVERTE EM UM RACK DE PAINEL LATERAL DE ENCAIXE RÁPIDO, ADICIONANDO O KIT 06RKIT (ADQUIRIDO SEPARADAMENTE)

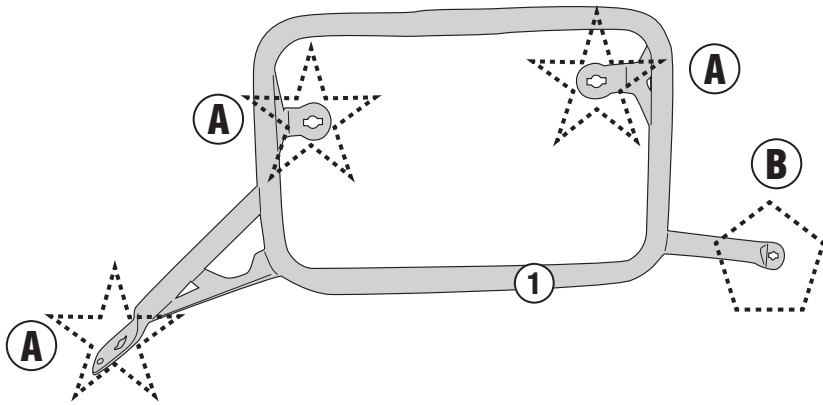

**ALWAYS MOUNT THE SCREWS FROM THE OUTSIDE OF THE FRAME**

### ★ TYPE A

(See the figure above for the correct type)

**CORRECT SIDE**



**INSERT**

ATTENTION TO THE CORRECT ASSEMBLY

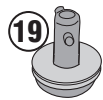
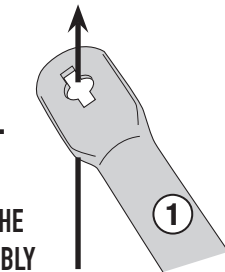

Z1957

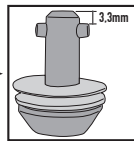

**INSERT**

19



ATTENTION TO THE CORRECT ASSEMBLY

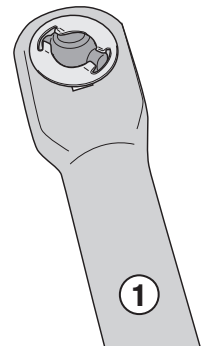
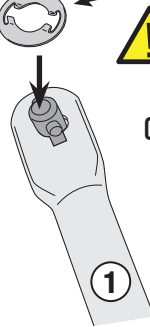

### ★ TYPE B

(See the figure above for the correct type)

**CORRECT SIDE**



**INSERT**

ATTENTION TO THE CORRECT ASSEMBLY

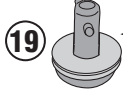
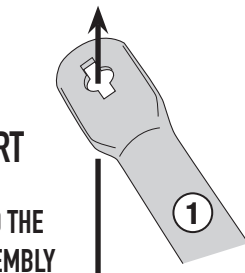

Z2173

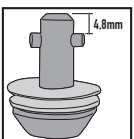

**INSERT**

19



ATTENTION TO THE CORRECT ASSEMBLY

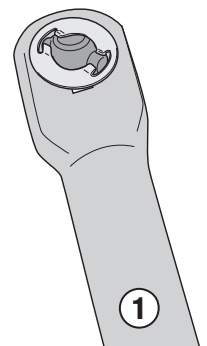
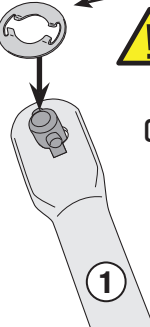
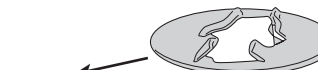



# PL03118MK - KL03118MK

PORTAVALIGIE LATERALE SPECIFICO - SPECIFIC TUBULAR SIDE-CASE HOLDER - PORTE-VALISES LATÉRAUX SPÉCIFIQUE  
SPEZIFISCHES STAHLROHR-SEITENTRAEGER - PORTA MALETAS LATERALES ESPECÍFICO - SUPORTE DE MALAS ESPECÍFICO

SUZUKI V-STROM 1050/ V-STROM 1050XT (2020-2023)/ V-STROM 1050DE (2023)

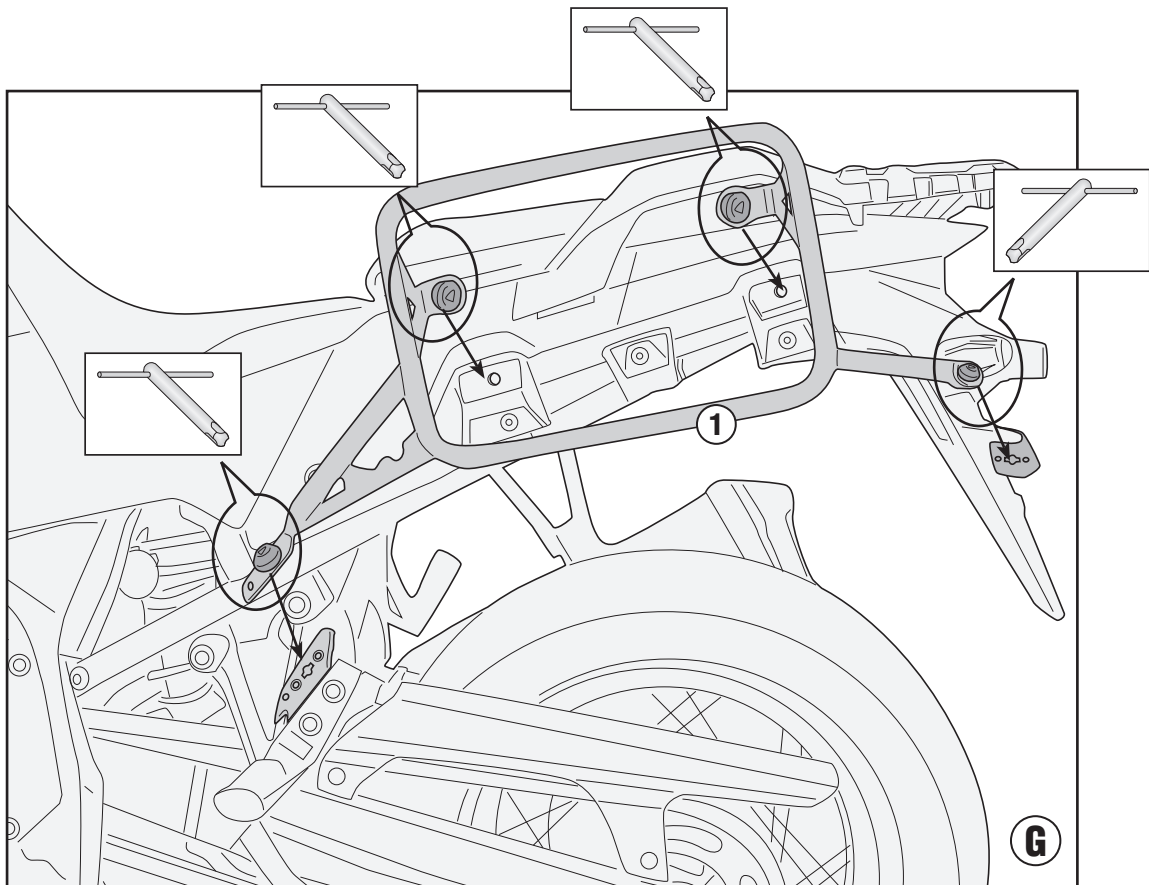
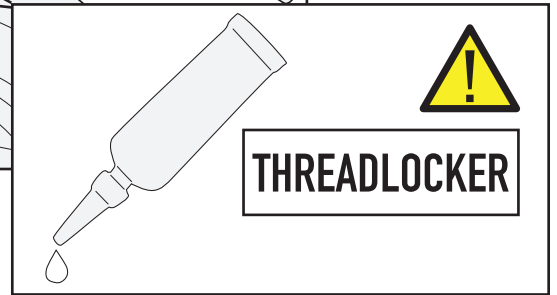
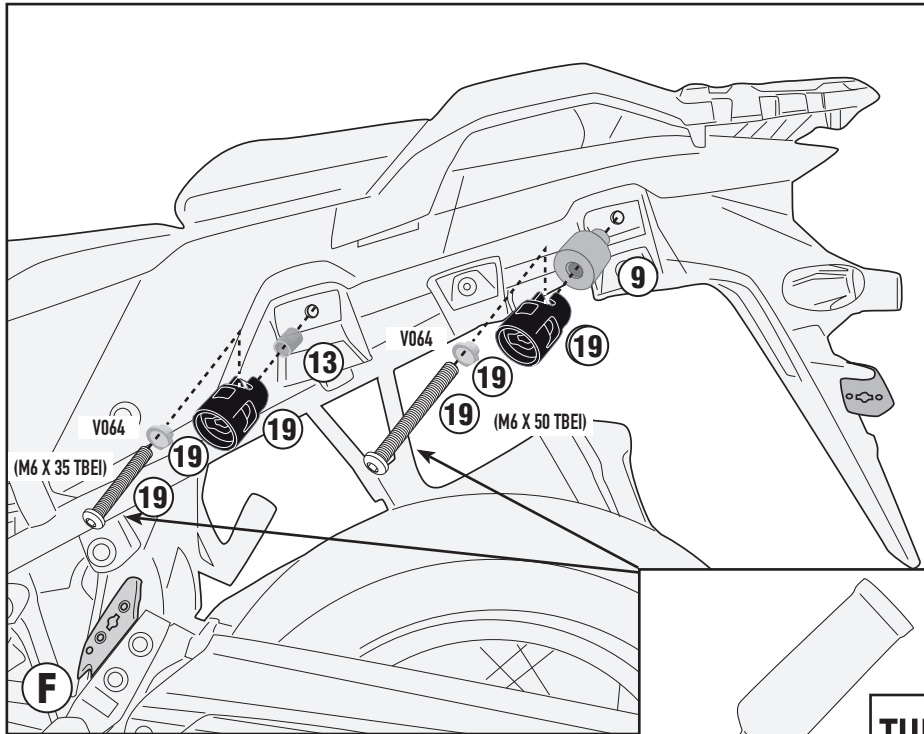

ISTRUZIONI DI MONTAGGIO - MOUNTING INSTRUCTIONS  
INSTRUCTIONS DE MONTAGE - BAUANLEITUNG  
INSTRUCCIONES DE MONTAJE - INSTRUÇÕES DE MONTAGEM



MONTAGGIO/SMONTAGGIO - ASSEMBLY/DISASSEMBLY - MONTAGE/DÉMONTAGE - MONTAGE/DEMONTAGE - MONTAJE/DESMONTAJE - MONTAGEM/DESMONTAGEM

# RAPID FITTING

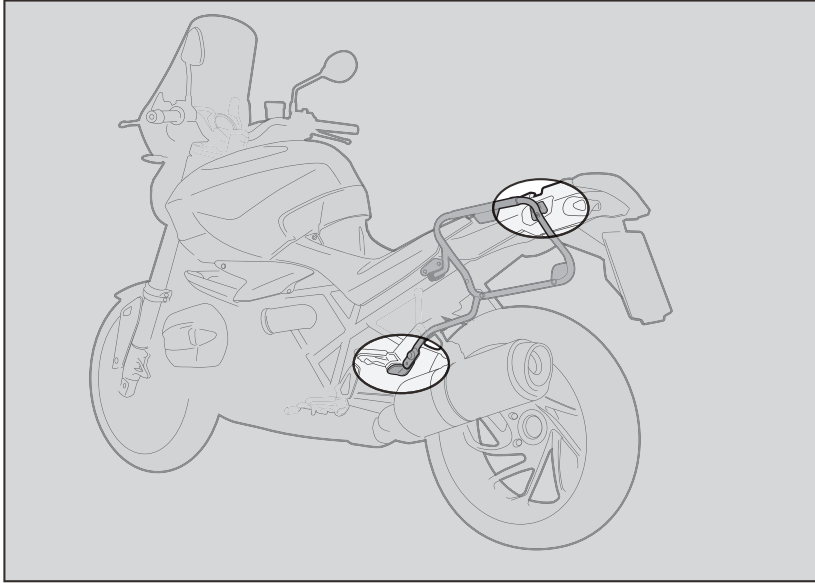

1. INSERIRE L'ATTREZZO NELLA TESTA DELLA VITE SPECIALE;
2. RUOTARE DI 1/4 DI GIRO IN SENSO ORARIO FINO A CHE LA ROTAZIONE NON TERMINA E SI AVVERTE LO SCATTO;
3. PER SMONTARE PROCEDERE IN SENSO INVERSO.

1. INSERT THE SPECIAL KEY INTO THE HEAD OF THE SCREW;
2. TURN THE KEY ¼ TURN CLOCKWISE UNTIL ROTATION STOPS AND THE SIDE CASE HOLDER IS FASTENED SECURELY TO THE FITMENT POINT;
3. IN ORDER TO DISASSEMBLE THE BRACKETRY PERFORM THE OPERATION IN REVERSE.

1. INSERER LA CLE SPECIALE DANS LA TETE DE LA VIS;
2. VISSER D'1/4 DE TOUR DANS LE SENS HORAIRE JUSQU'AU BLOCAGE DE LA VIS POUR MONTER EN TOUTE SECURITE LE SUPPORT A SON POINT DE FIXATION;
3. POUR LE DEMONTAGE, PROCEDER EN SENSE INVERSE.

1. STECKEN SIE DAS WERKZEUG IN DEN KOPF DER SPEZIFISCHEN SCHRAUBE;
2. DREHEN SIE DIE SCHRAUBE 1 / 4 UMDREHUNG IM UHRZEIGERSINN BIS SIE BEMERKEN, DASS DIE SCHRAUBE IM BEFESTIGUNGSPUNKT EINGEKLEMMT IST;
3. FÜR DIE DEMONTAGE FOLGEN SIE DEN HINWEISE UMGEKEHRT.

1. INSERTAR LA LLAVE ESPECIAL EN LA CABEZA DEL TORNILLO
2. DAR ¼ DE VUELTA EN EL SENTIDO HORARIO HASTA QUE LLEGUE AL TOPE Y SE VEA EL TORNILLO;
3. PARA DESMONTARLO PROCEDER EN LA DIRECCIÓN CONTRARIA;

## MONTAGGIO - ASSEMBLY - MONTAGE - MONTAGE - MONTAJE

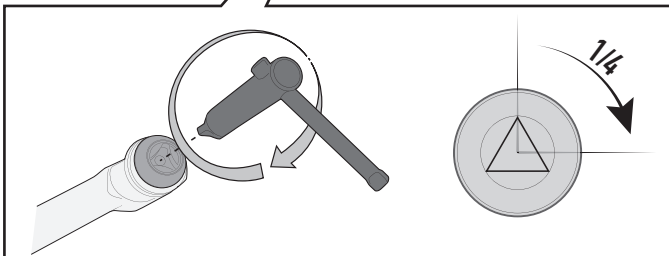
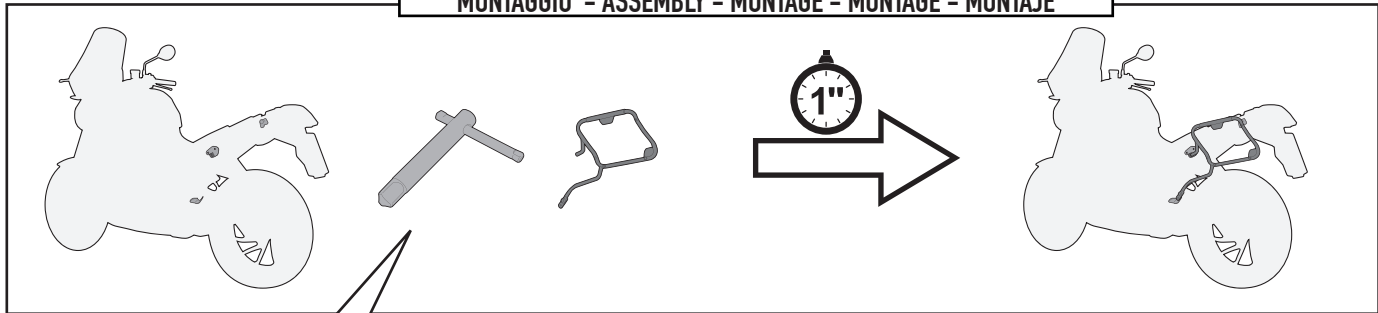

## SMONTAGGIO - DISASSEMBLY - DÉMONTAGE - DEMONTAGE - DESMONTAJE

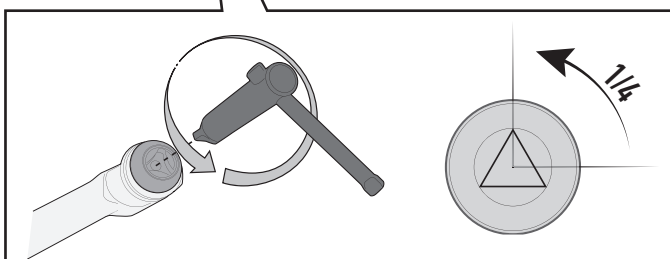
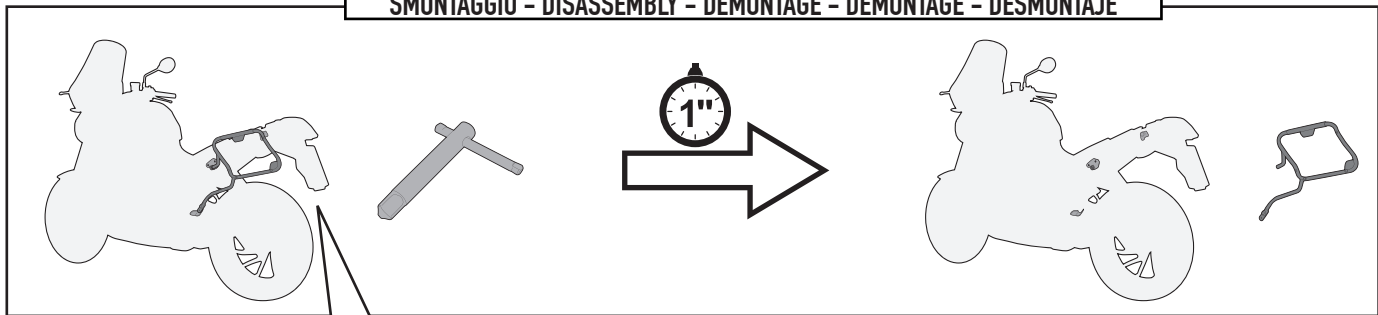

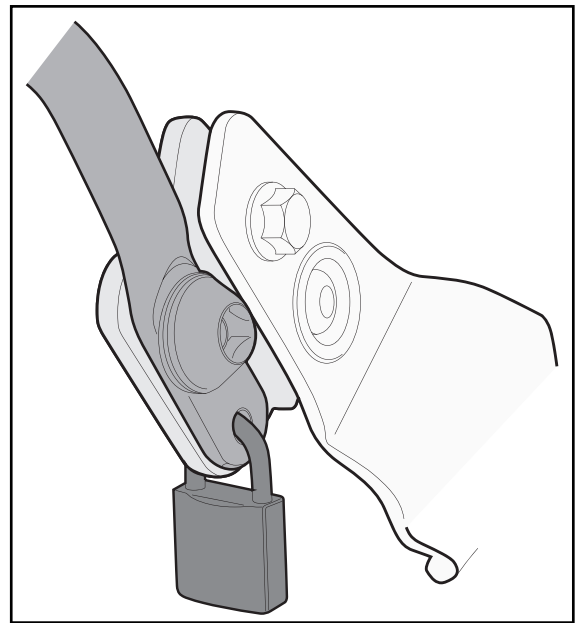
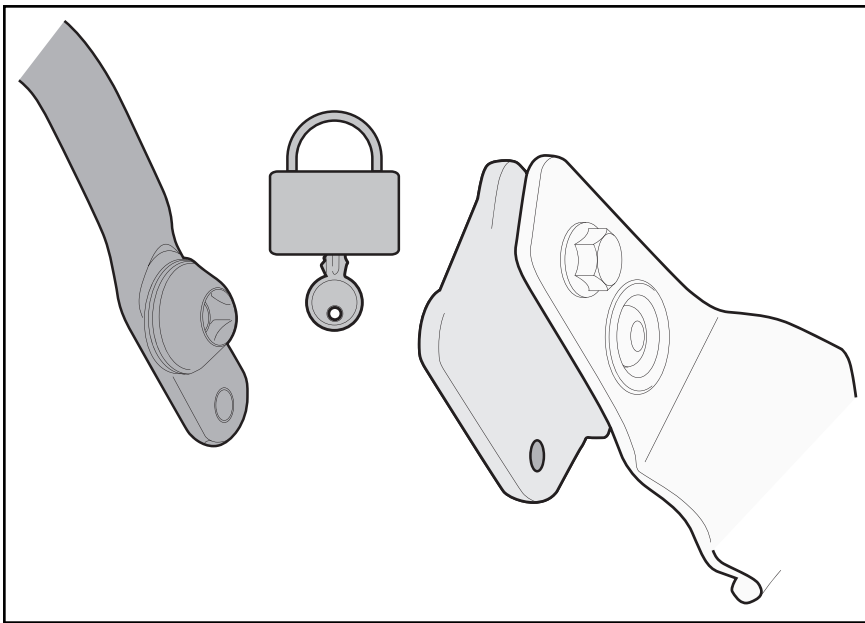
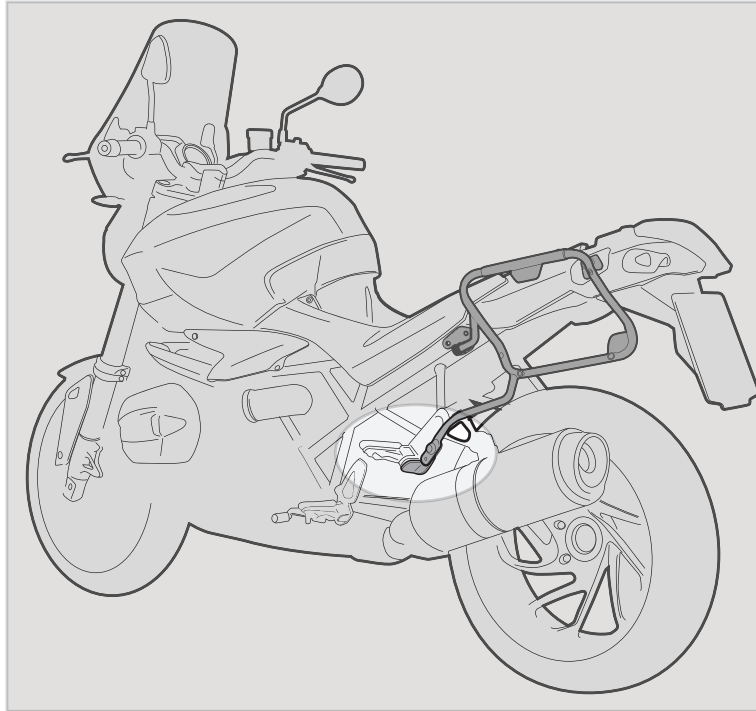

## FORO DI SICUREZZA

FORO PREDISPOSTO AD ASSICURARE IL PORTAVALIGE LATERALE ALLA MOTO (CON UN LUCCHETTO PER ESEMPIO, NON INCLUSO).

## SECURITY HOLE

HOLE PLACEMENT IN ORDER TO INCREASE SECURITY OF THE TUBULAR SIDE-CASE HOLDER TO THE MOTORCYCLE (WITH A LOCK, FOR EXAMPLE, NOT INCLUDED).

## TROU DE SECURITE

TROU PREDISPOSE POUR ASSURER LE PORTE-VALISE LATERAL A LA MOTO (AVEC UN CADENAS PAR EXEMPLE, NON INCLUS).

## SICHERHEITSLÖCH

VORGESEHENES LOCH UM DEN SEITENKOFFER TRÄGER AN DEM FAHRZEUG ZU SICHERN (Z. B. MIT EINEM VORHÄNGESCHLOSS, NICHT ENTHALTEN).

## ORIFICIO DE SEGURIDAD

ESTE ORIFICIO ESTA CREADO PARA ASEGURAR EL PORTAEQUIPAJES LATERAL A LA MOTO (POR EJEMPLO CON UN CANDADO, QUE NO ESTÁ INCLUIDO).