

PL08209CAM - KL08209CAM

PORTAVALIGIE LATERALE SPECIFICO - SPECIFIC TUBULAR SIDE-CASE HOLDER - PORTE-VALISES LATÉRAUX SPÉCIFIQUE
SPEZIFISCHES STAHLROHR-SEITENTRAEGER - PORTA MALETAS LATERALES ESPECÍFICO - SUPORTE DE MALAS ESPECÍFICO

N°	Descrizione/Description	Caratteristiche/Features	Codice/Code	Quantità/quantity
1	Telaio laterale - Side frame - Châssis latéral Soporte lateral - Seitenrahmen - Suporte lateral	-	PL08209DXV PL08209SXV	2 (Right: Left)
2	Ponte - Bridge - Pont - Brücke - Puente - Ponte	-	GL5877V	1
3	Supporto inferiore - Lower support - Support inférieur Soporte inferior - Untere Halterung - Suporte inferior	-	GL5876DXV GL5876SXV	2 (Right: Left)
4	Vite - Screw - Vis - Schraube Tornillo - Parafuso	TBEI M8x75	875TBEI	4
5	Vite - Screw - Vis - Schraube Tornillo - Parafuso	TBEI M8x25	825TBEI	4
6	Vite - Screw - Vis - Schraube Tornillo - Parafuso	TECF M6x20	620TECF	4
7	Rondella spaccata - Split washer - Scheibe - Rondelle fendue Arandela seccionada - Arruela Dentada	Foro Ø8mm	Z1060	4
8	Rondella - Washer - Rondelle - Scheibe Arandela - Arruela	Foro Ø8mm Esterno Ø20mm Sp.2mm	820RON	16
9	Rondella - Washer - Rondelle - Scheibe Arandela - Arruela	Foro Ø6mm	6RON	4
10	Rondella - Washer - Rondelle - Scheibe Arandela - Arruela	Foro Ø5mm	5RON	3
11	Rondella - Washer - Rondelle - Scheibe Arandela - Arruela	Foro Ø5mm / Esterno Ø15mm	515RON	6
12	Distanziale - Spacer - Entretoise - Distanzstueck Distanciador - Espaçador	Ø16x10 Foro 8,5mm	C16L10F8.5T	2
13	Distanziale - Spacer - Entretoise - Distanzstueck Distanciador - Espaçador	Ø16x14 Foro 8,5mm	C16L14F8.5T	2
14	Dado - Bolt - Ecrou Mutter - Tuerca - Porca	Dado Autobloccante Flangiato M8 (H.9,5mm)	8DADIFN	4
15	Tappo - Cap - Fiche - Stecker Enchufe - Capa	-	13COP	4
16	Boccola - Mounting bush - Entretoise de montage Cilindro de fijación - Montagehülse - Bucha de fixação	-	Z4039	4
17	Rivetto - Rivet - Rivet Niet - Remache - Rebite	Alluminio 4,8x20mm	4.8L20RIV	4
18	Connettore maschio - Male connector - Connecteur mâle - Conector macho - Stecker männlich - Plugue macho	-	Z2424	4
19	Connettore femmina - Female connector - Connecteur femelle Conector hembra - Stecker weiblich - Plugue fêmea	-	Z2425	4
20	Prolunga - Extension cord - Rallonge électrique - Cable de extensión Verlängerungskabel - Cabo de extensão	-	Z2446	2
21	Componenti Originali - Original Parts - Parties Originales Original Bauteile - Componentes Originales - Componentes Originais	-	-	-
22	Particolari Inclusi nel 14RKIT - Components Included In The 14RKIT Pièces Incluses Dans 14RKIT - Die Einzelnen Teile Sind Bei 14RKIT Despieces Incluidos 14RKIT - Componentes incluidos na 14RKIT	-	-	-
23	Vite - Screw - Vis - Schraube Tornillo - Parafuso	TBEI M5x25	525TBEI	3
24	Dado - Bolt - Ecrou Mutter - Tuerca - Porca	Dado Autobloccante M5	5DADIAU	3
25	Distanziale - Spacer - Entretoise - Distanzstueck Distanciador - Espaçador	Ø10x3 Foro 6,5mm	C10L3F6.5T	1

PL08209CAM - KL08209CAM

PORTAVALIGIE LATERALE SPECIFICO - SPECIFIC TUBULAR SIDE-CASE HOLDER - PORTE-VALISES LATÉRAUX SPÉCIFIQUE
 SPEZIFISCHES STAHLROHR-SEITENTRAEGER - PORTA MALETAS LATERALES ESPECÍFICO - SUPORTE DE MALAS ESPECÍFICO

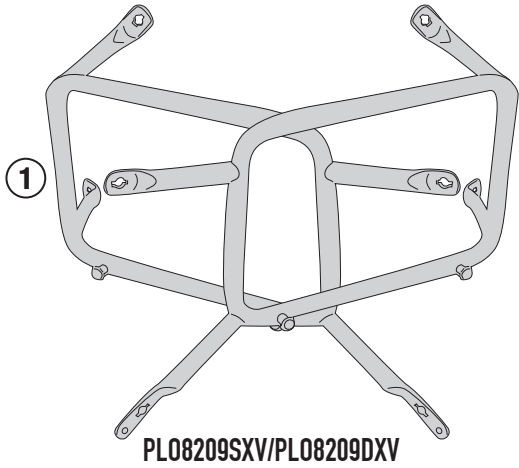

PL08209SXV/PL08209DXV

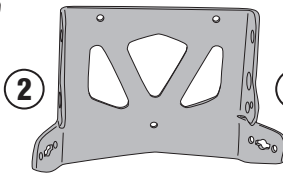

GL5877V

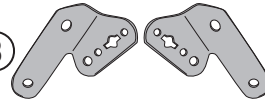

GL5876DXV/GL5876SXV

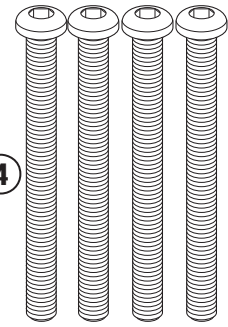

M8x75mm

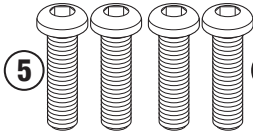

M8x25mm

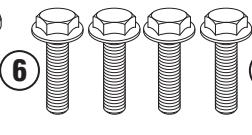

M6x20mm



Hole Ø8mm

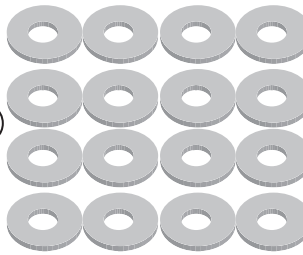

Hole Ø8mm/
External Ø20mm/
D.2mm



Hole Ø6mm



Hole Ø5mm



Hole Ø5mm/
External Ø15mm



Hole Ø8.5mm/
External Ø16mm/
H.10mm



Hole Ø8.5mm/
External Ø16mm/
H.14mm

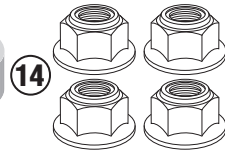

M8

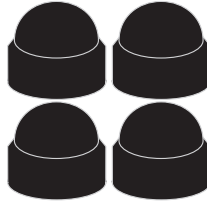

13COP

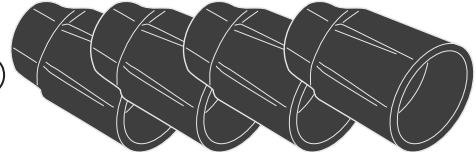

Z4039

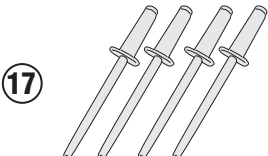

4.8L20RIV

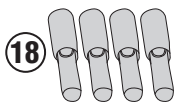

Z2424



Z2425

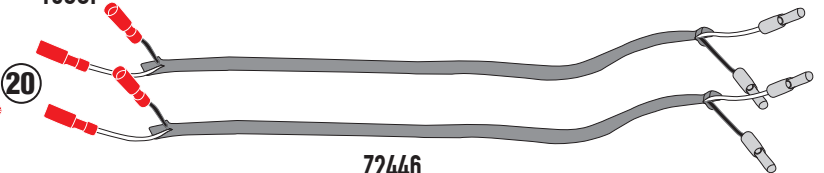

Z2446

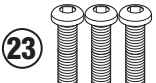

M5x25mm



M5



Hole Ø6.5mm/
External Ø10mm/
H.3mm

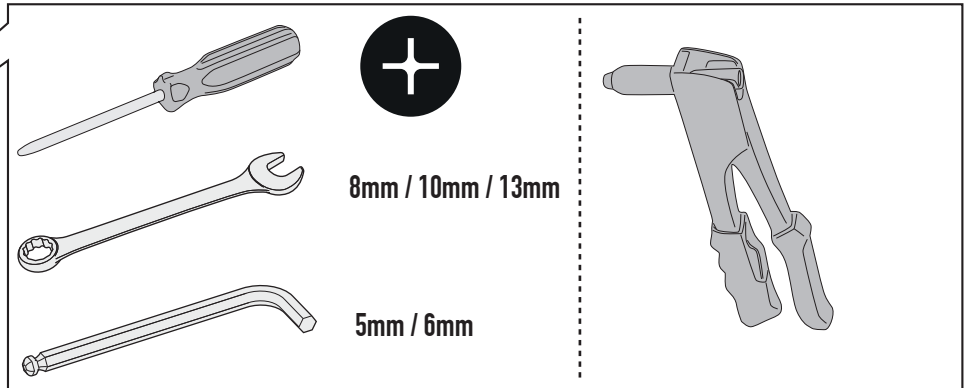
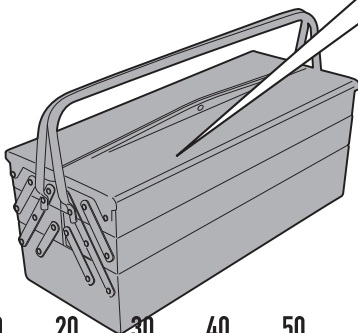

8mm / 10mm / 13mm

5mm / 6mm

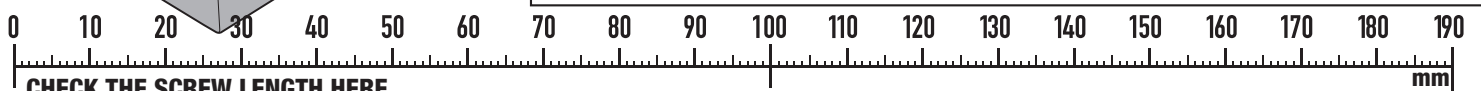

CHECK THE SCREW LENGTH HERE

ISTRUZIONI DI MONTAGGIO - MOUNTING INSTRUCTIONS
 INSTRUCTIONS DE MONTAGE - BAUANLEITUNG
 INSTRUCCIONES DE MONTAJE - INSTRUÇÕES DE MONTAGEM

PL08209CAM - KL08209CAM

PORTAVALIGIE LATERALE SPECIFICO - SPECIFIC TUBULAR SIDE-CASE HOLDER - PORTE-VALISES LATÉRAUX SPÉCIFIQUE
SPEZIFISCHES STAHLROHR-SEITENTRAEGER - PORTA MALETAS LATERALES ESPECÍFICO - SUPORTE DE MALAS ESPECÍFICO

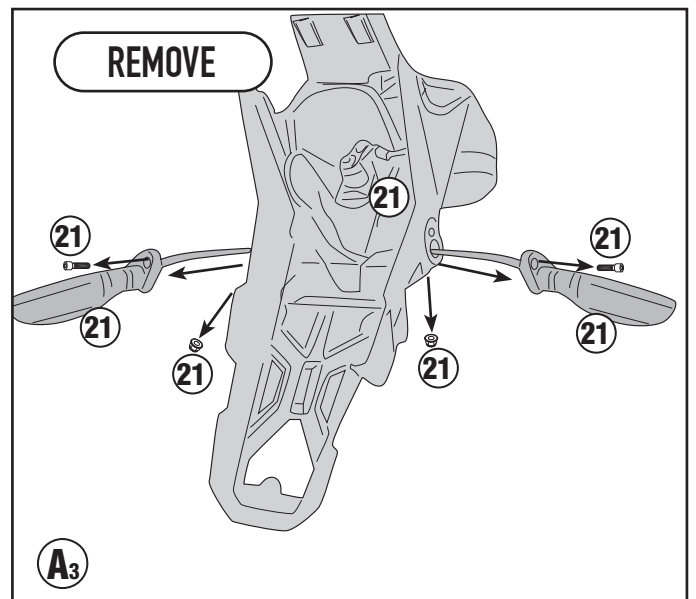
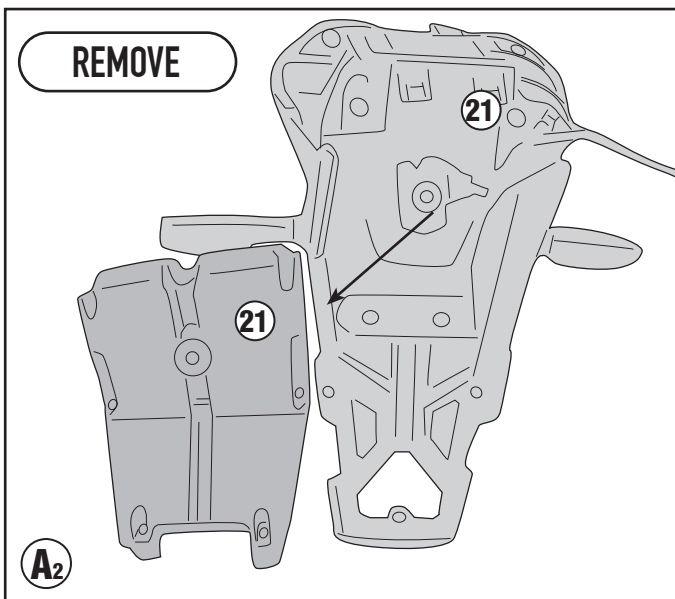
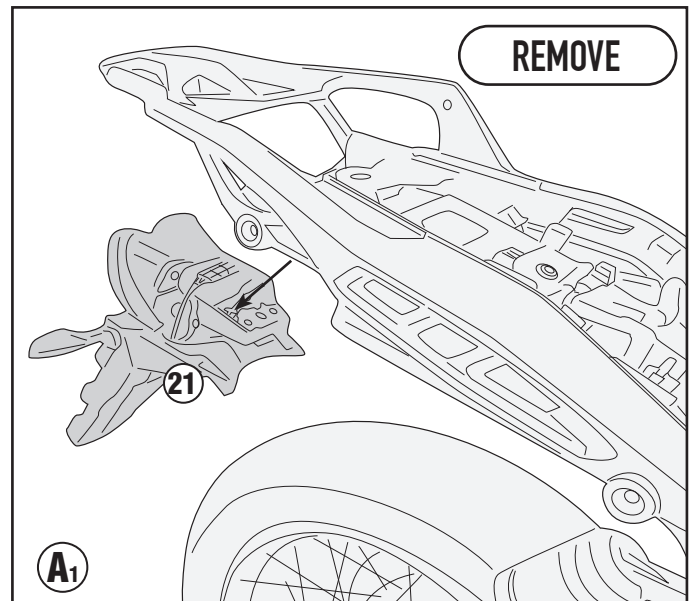
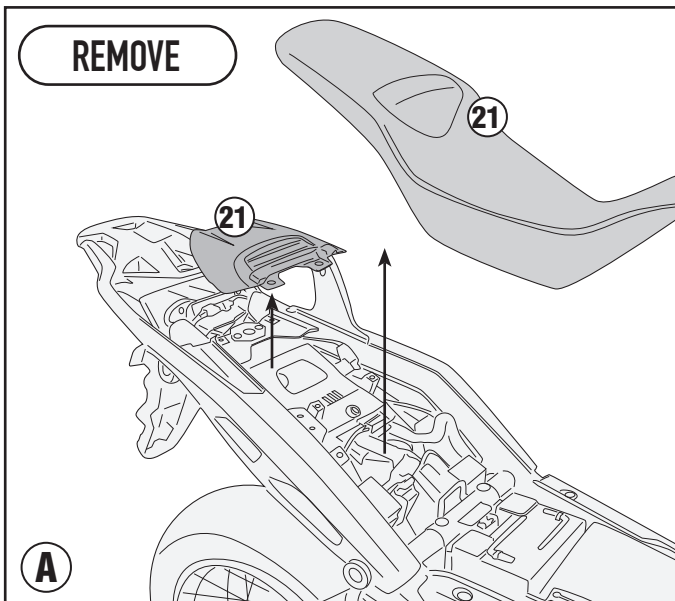
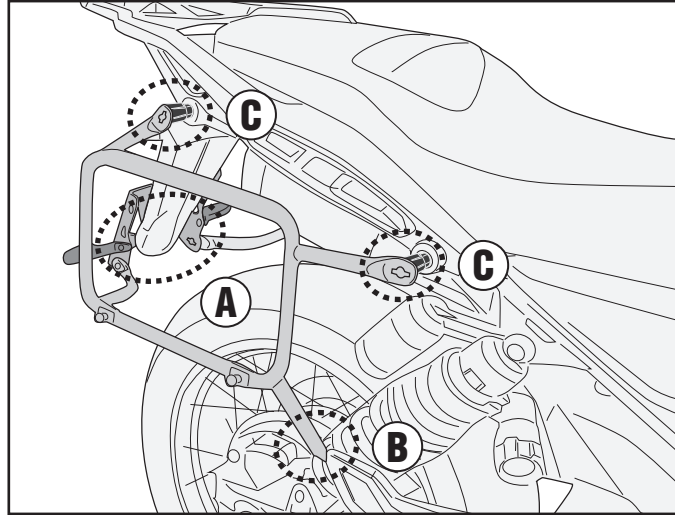

PL08209CAM - KL08209CAM

PORTAVALIGIE LATERALE SPECIFICO - SPECIFIC TUBULAR SIDE-CASE HOLDER - PORTE-VALISES LATÉRAUX SPÉCIFIQUE
 SPEZIFISCHES STAHLROHR-SEITENTRAEGER - PORTA MALETAS LATERALES ESPECÍFICO - SUPORTE DE MALAS ESPECÍFICO

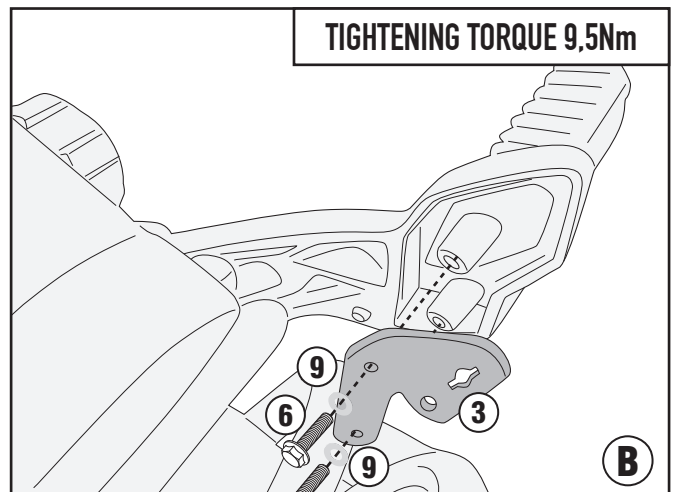
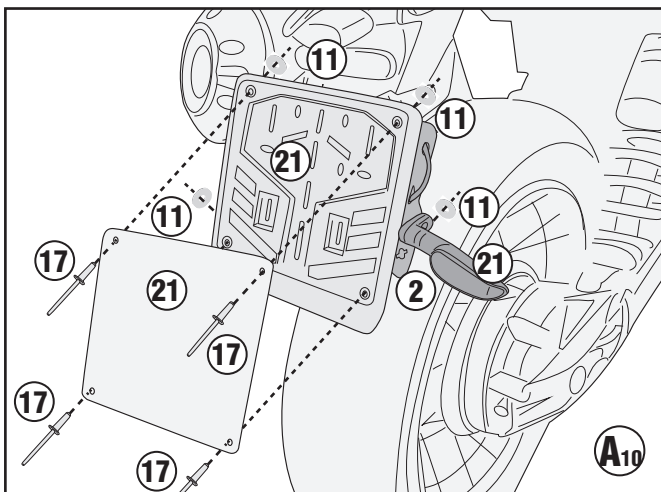
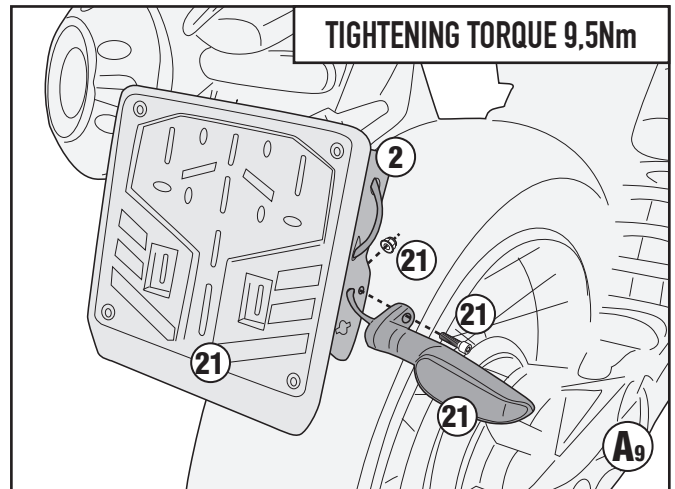
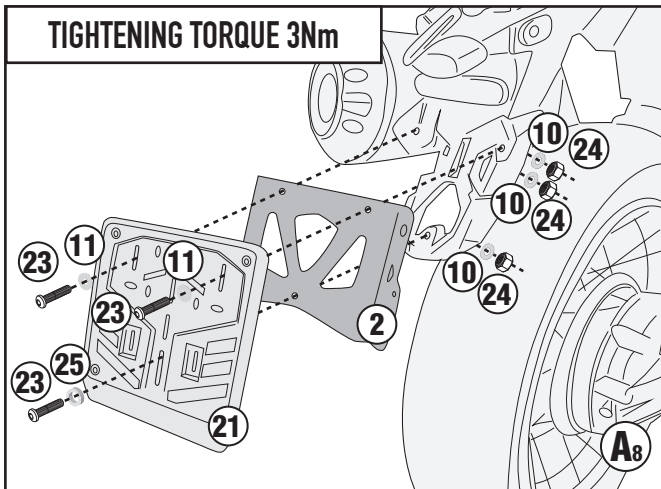
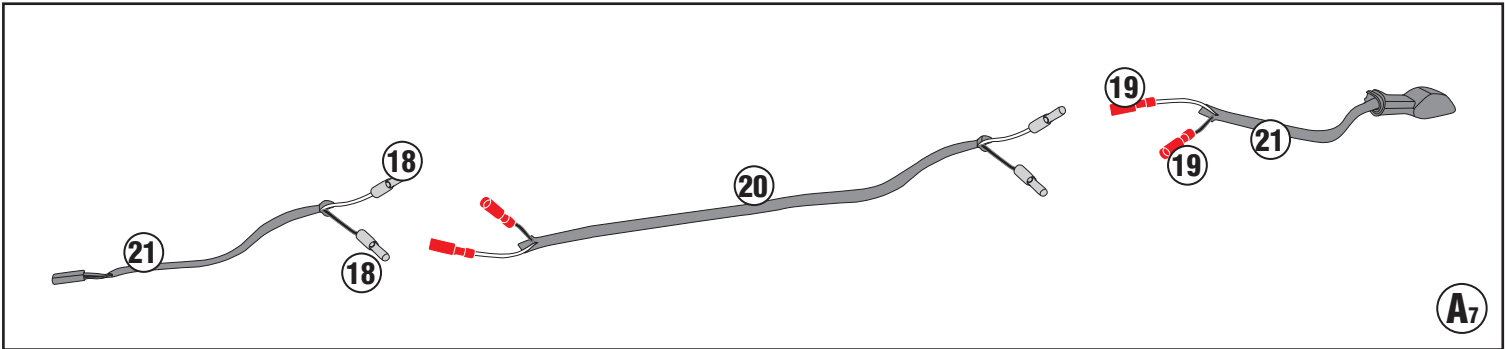
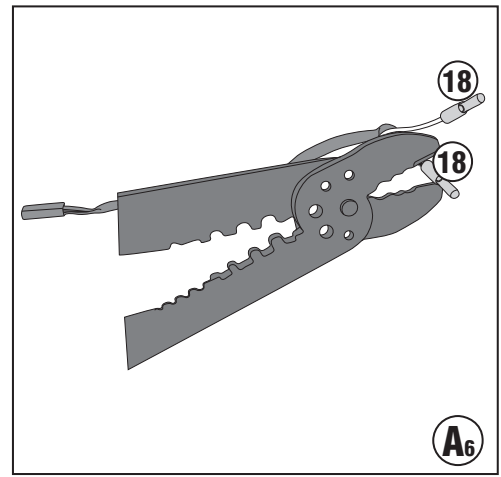
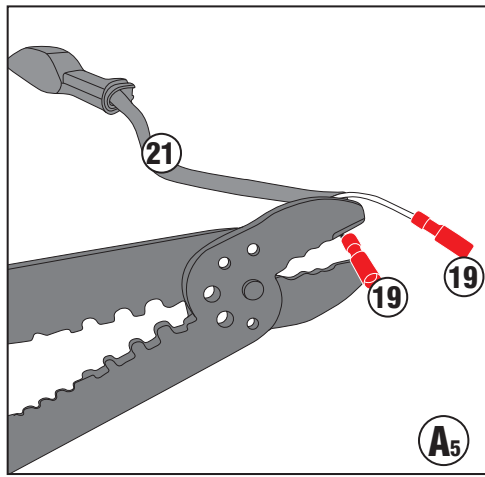
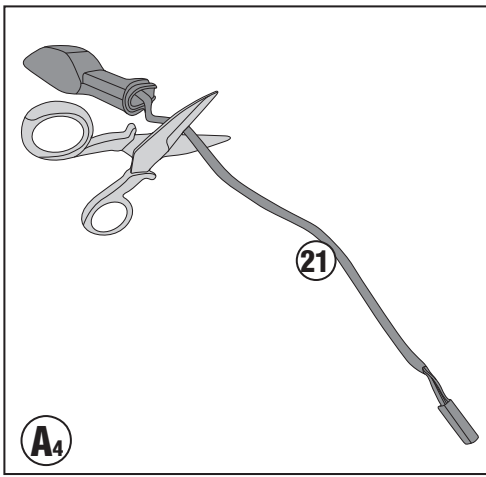

PL08209CAM - KL08209CAM

PORTAVALIGIE LATERALE SPECIFICO - SPECIFIC TUBULAR SIDE-CASE HOLDER - PORTE-VALISES LATÉRAUX SPÉCIFIQUE
SPEZIFISCHES STAHLROHR-SEITENTRAEGER - PORTA MALETAS LATERALES ESPECÍFICO - SUPORTE DE MALAS ESPECÍFICO

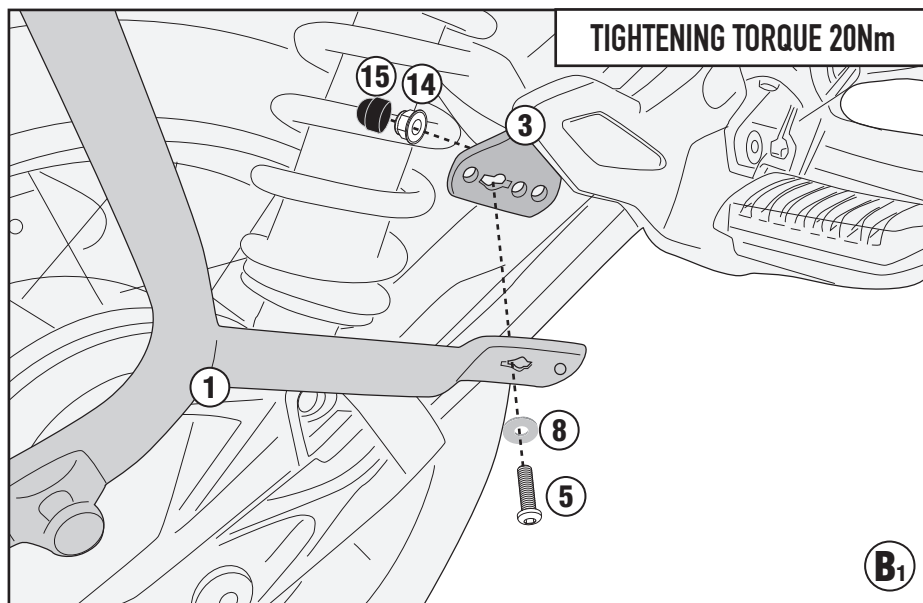
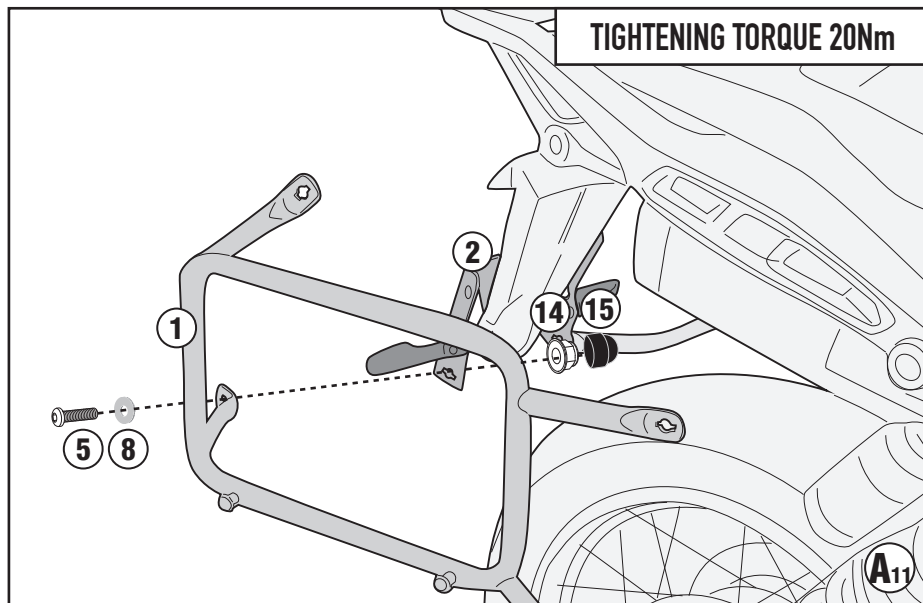
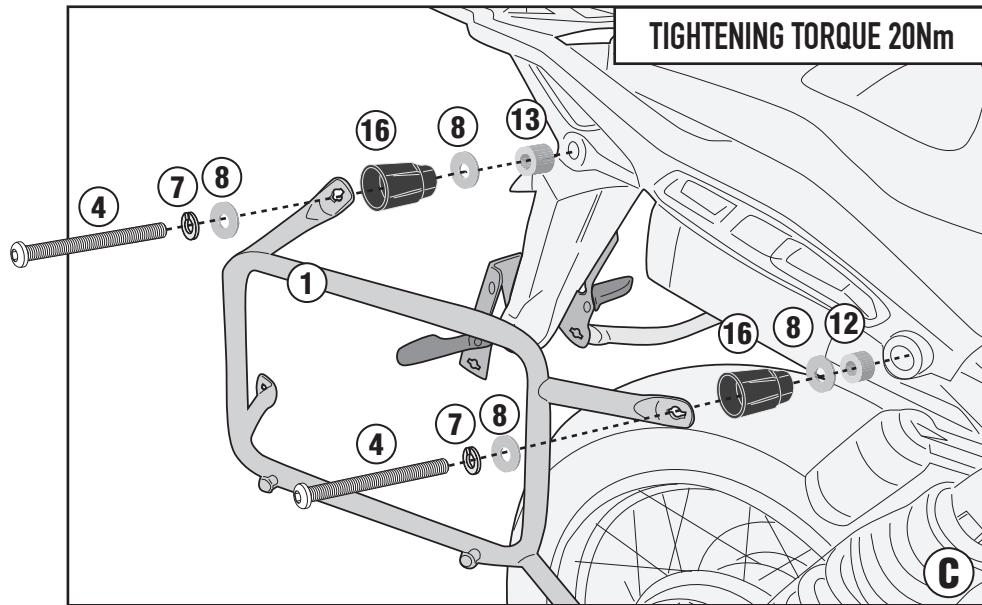

ISTRUZIONI DI MONTAGGIO - MOUNTING INSTRUCTIONS
INSTRUCTIONS DE MONTAGE - BAUANLEITUNG
INSTRUCCIONES DE MONTAJE - INSTRUÇÕES DE MONTAGEM

PL08209CAM - KL08209CAM

PORTAVALIGIE LATERALE SPECIFICO - SPECIFIC TUBULAR SIDE-CASE HOLDER - PORTE-VALISES LATÉRAUX SPÉCIFIQUE
SPEZIFISCHES STAHLROHR-SEITENTRÄGER - PORTA MALETAS LATERALES ESPECÍFICO - SUPORTE DE MALAS ESPECÍFICO

- TRASFORMAZIONE IN PORTAVALIGIE LATERALI RAPID FITTING, AGGIUNDO IL KIT 14RKIT (DA ACQUISTARE SEPARATAMENTE)
- TRANSFORMATION INTO A RAPID FITTING SIDE-CASE HOLDER, BY ADDING THE 14RKIT KIT (TO BE PURCHASED SEPARATELY)
- VERARBEITUNG ZU EINEM SCHNELL MONTIERBAREN SEITENTRÄGER UNTER HINZUFÜGUNG DES 14RKIT-KITS (SEPARAT ZU ERWERBEN)
- TRANSFORMABLE EN KIT DE FIXATION LATÉRAL RAPIDE, EN AJOUTANT LE KIT 14RKIT (À ACHETER SÉPARÉMENT)
- SE TRANSFORMA EN UN PORTAMALETAS LATERAL DE AJUSTE RÁPIDO, AÑADIENDO EL KIT 14RKIT (SE COMPRA POR SEPARADO)
- CONVERTE EM UM RACK DE PAINEL LATERAL DE ENCAIXE RÁPIDO, ADICIONANDO O KIT 14RKIT (ADQUIRIDO SEPARADAMENTE)

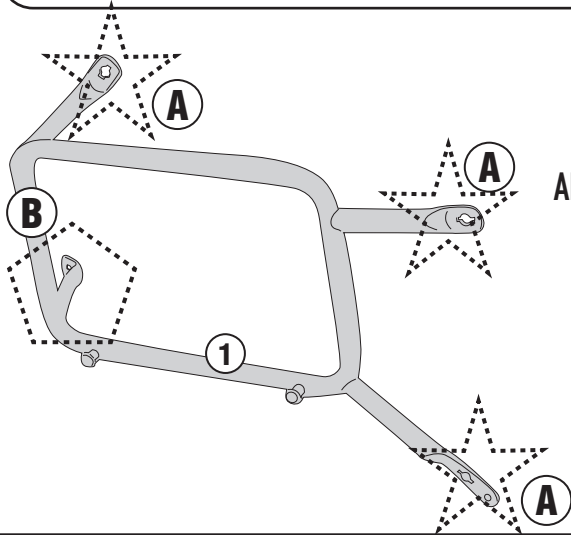

ALWAYS MOUNT THE SCREWS FROM
THE OUTSIDE OF THE FRAME

★ TYPE A

(See the figure above for the correct type)

CORRECT SIDE



INSERT

ATTENTION TO THE
CORRECT ASSEMBLY

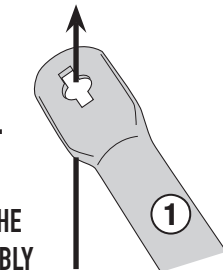

Z1957

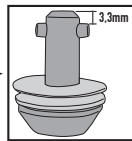

INSERT

22



ATTENTION TO THE
CORRECT ASSEMBLY

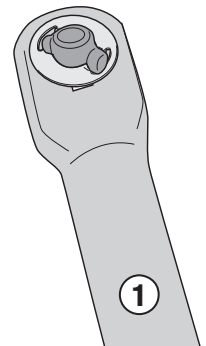
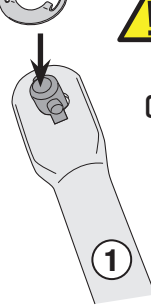

★ TYPE B

(See the figure above for the correct type)

CORRECT SIDE



INSERT

ATTENTION TO THE
CORRECT ASSEMBLY

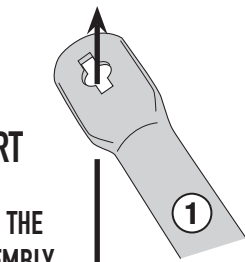

Z2173

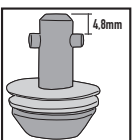

INSERT

22



ATTENTION TO THE
CORRECT ASSEMBLY

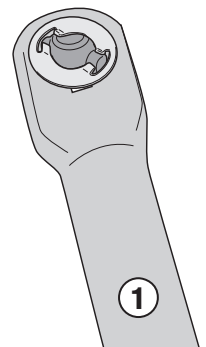
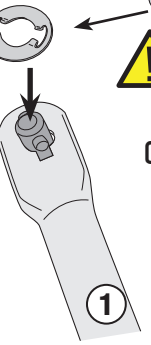

PL08209CAM - KL08209CAM

PORTAVALIGIE LATERALE SPECIFICO - SPECIFIC TUBULAR SIDE-CASE HOLDER - PORTE-VALISES LATÉRAUX SPÉCIFIQUE
SPEZIFISCHES STAHLROHR-SEITENTRAEGER - PORTA MALETAS LATERALES ESPECÍFICO - SUPORTE DE MALAS ESPECÍFICO

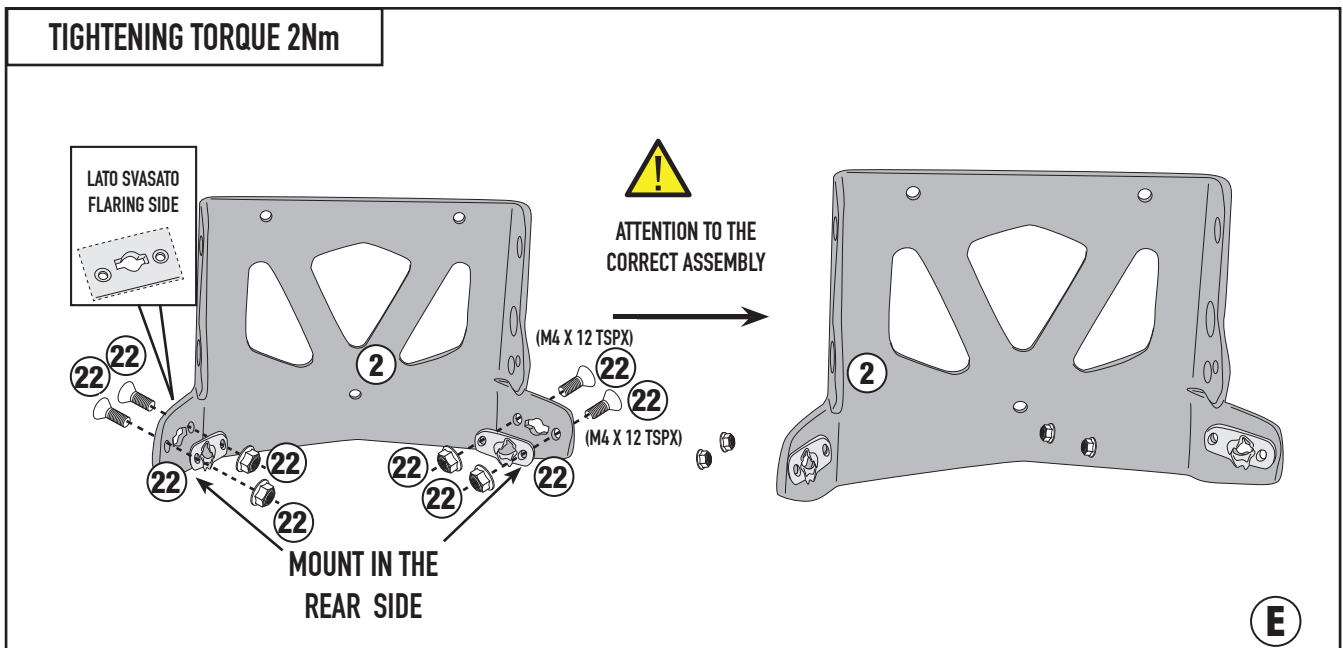
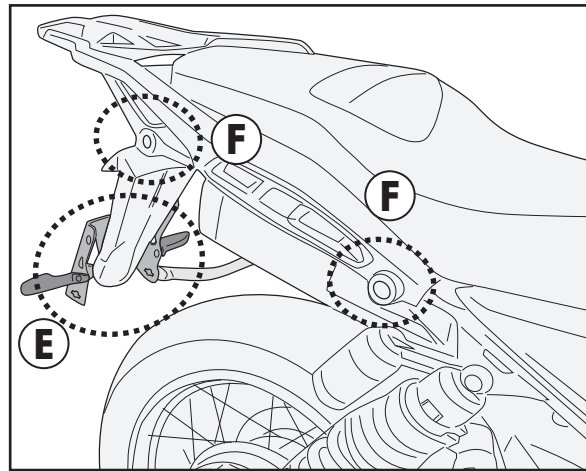
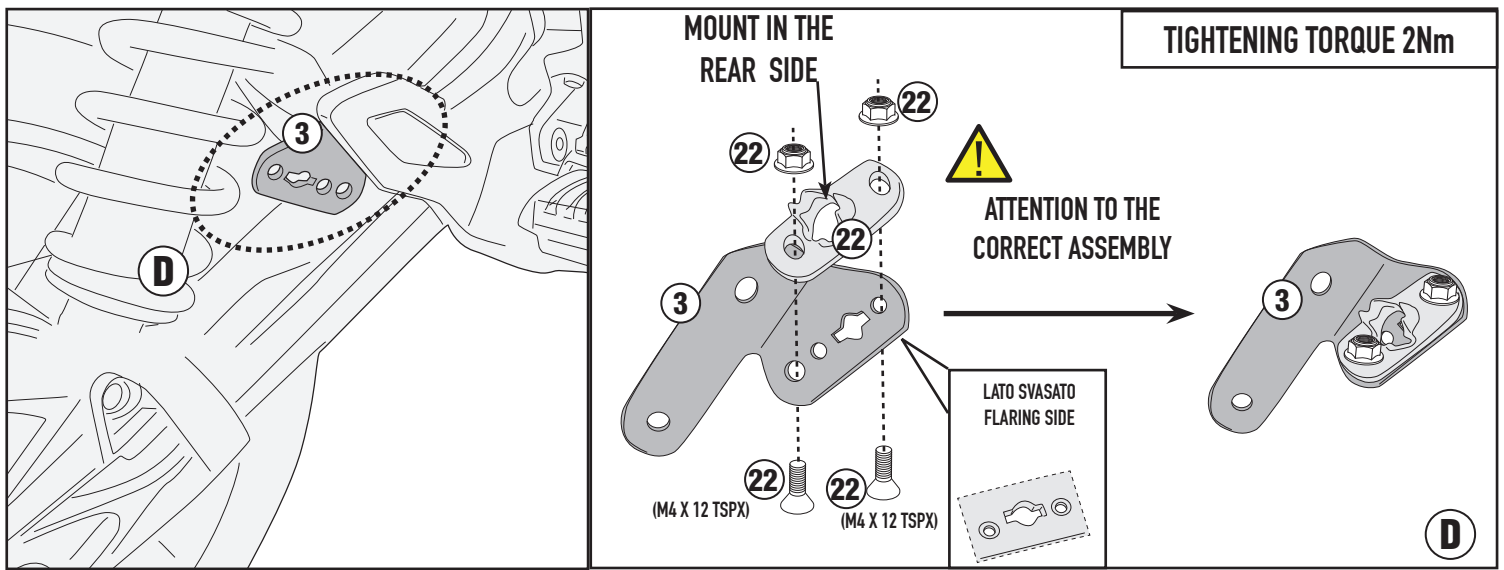

PL08209CAM - KL08209CAM

PORTAVALIGIE LATERALE SPECIFICO - SPECIFIC TUBULAR SIDE-CASE HOLDER - PORTE-VALISES LATÉRAUX SPÉCIFIQUE
SPEZIFISCHES STAHLROHR-SEITENTRAEGER - PORTA MALETAS LATERALES ESPECÍFICO - SUPORTE DE MALAS ESPECÍFICO

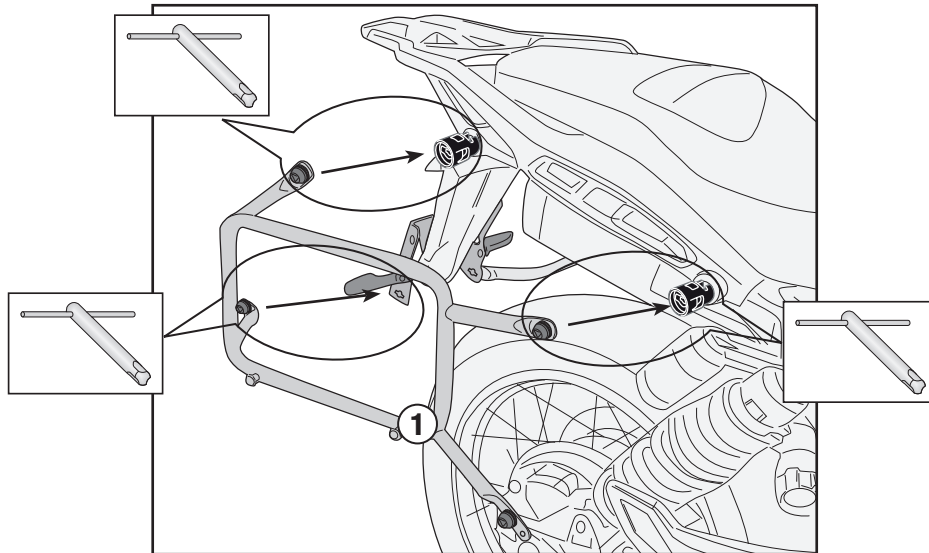
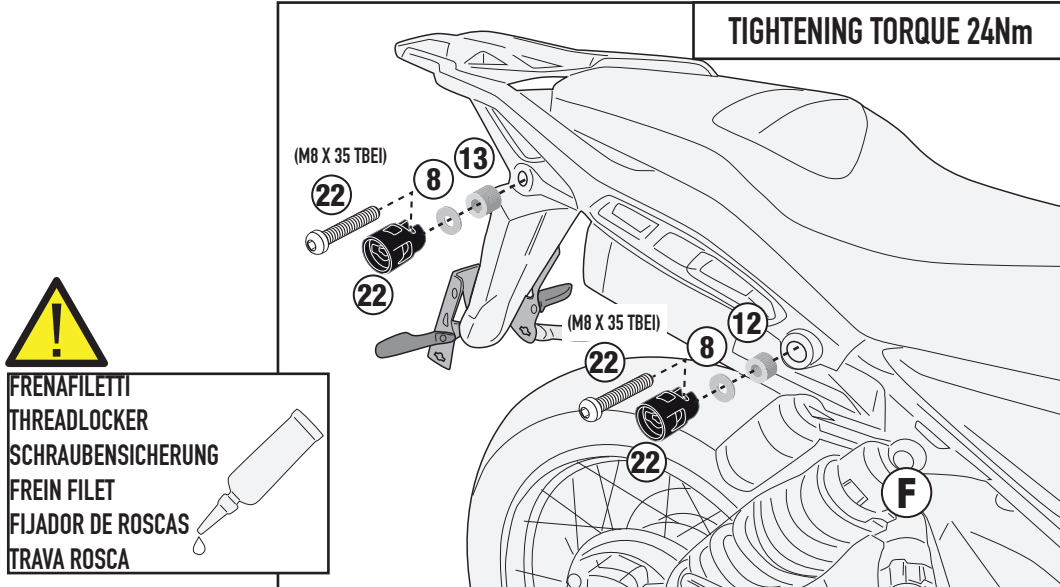

MONTAGGIO/SMONTAGGIO - ASSEMBLY/DISASSEMBLY - MONTAGE/DÉMONTAGE - MONTAGE/DEMONTAGE - MONTAJE/DESMONTAJE - MONTAGEM/DESMONTAGEM

RAPID FITTING

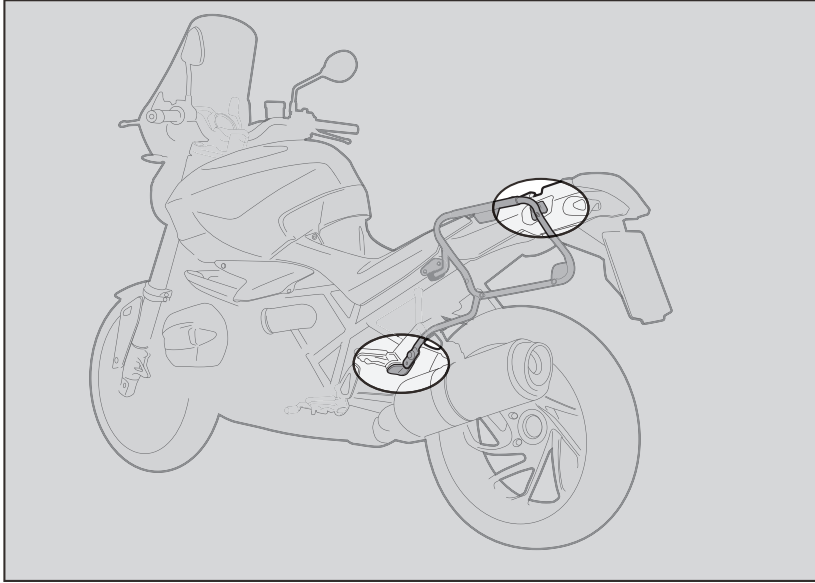

1. INSERIRE L'ATTREZZO NELLA TESTA DELLA VITE SPECIALE;
2. RUOTARE DI 1/4 DI GIRO IN SENSO ORARIO FINO A CHE LA ROTAZIONE NON TERMINA E SI AVVERTE LO SCATTO;
3. PER SMONTARE PROCEDERE IN SENSO INVERSO.

1. INSERT THE SPECIAL KEY INTO THE HEAD OF THE SCREW;
2. TURN THE KEY ¼ TURN CLOCKWISE UNTIL ROTATION STOPS AND THE SIDE CASE HOLDER IS FASTENED SECURELY TO THE FITMENT POINT;
3. IN ORDER TO DISASSEMBLE THE BRACKETRY PERFORM THE OPERATION IN REVERSE.

1. INSERER LA CLE SPECIALE DANS LA TETE DE LA VIS;
2. VISSER D'1/4 DE TOUR DANS LE SENS HORAIRE JUSQU'AU BLOCAGE DE LA VIS POUR MONTER EN TOUTE SECURITE LE SUPPORT A SON POINT DE FIXATION;
3. POUR LE DEMONTAGE, PROCEDER EN SENSE INVERSE.

1. STECKEN SIE DAS WERKZEUG IN DEN KOPF DER SPEZIFISCHEN SCHRAUBE;
2. DREHEN SIE DIE SCHRAUBE 1 / 4 UMDREHUNG IM UHRZEIGERSINN BIS SIE BEMERKEN, DASS DIE SCHRAUBE IM BEFESTIGUNGSPUNKT EINGEKLEMMT IST;
3. FÜR DIE DEMONTAGE FOLGEN SIE DEN HINWEISE UMGEKEHRT.

1. INSERTAR LA LLAVE ESPECIAL EN LA CABEZA DEL TORNILLO
2. DAR ¼ DE VUELTA EN EL SENTIDO HORARIO HASTA QUE LLEGUE AL TOPE Y SE VEA EL TORNILLO;
3. PARA DESMONTARLO PROCEDER EN LA DIRECCIÓN CONTRARIA;

MONTAGGIO - ASSEMBLY - MONTAGE - MONTAGE - MONTAJE

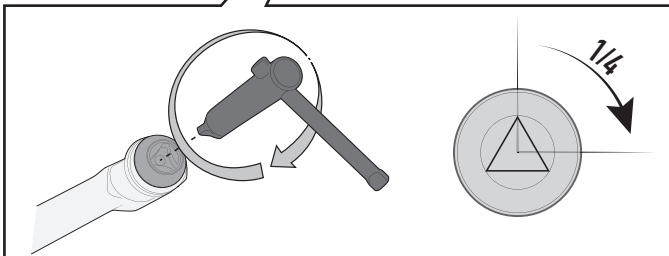
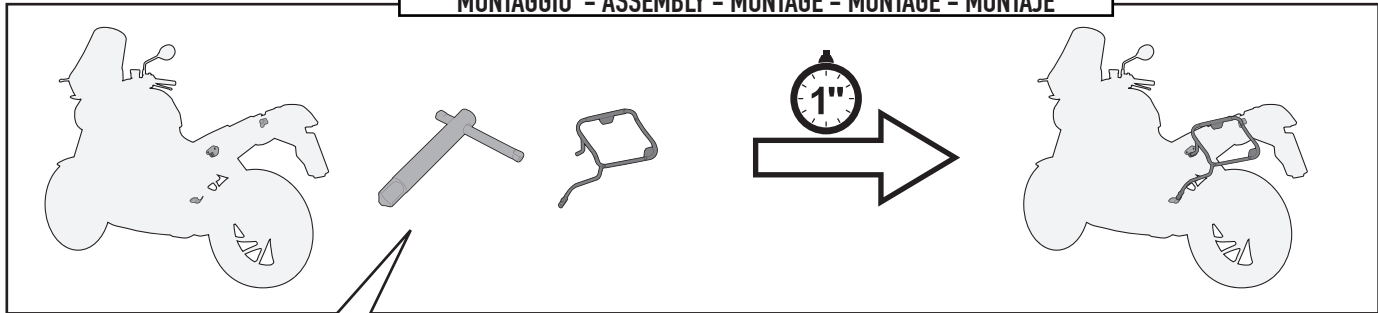

SMONTAGGIO - DISASSEMBLY - DÉMONTAGE - DEMONTAGE - DESMONTAJE

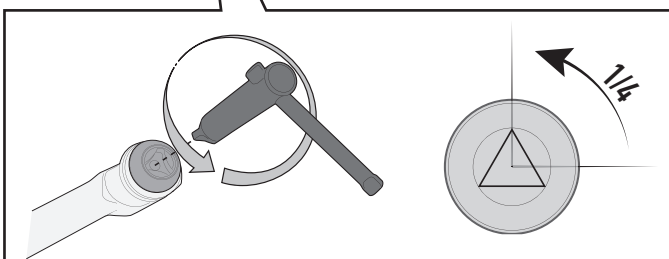
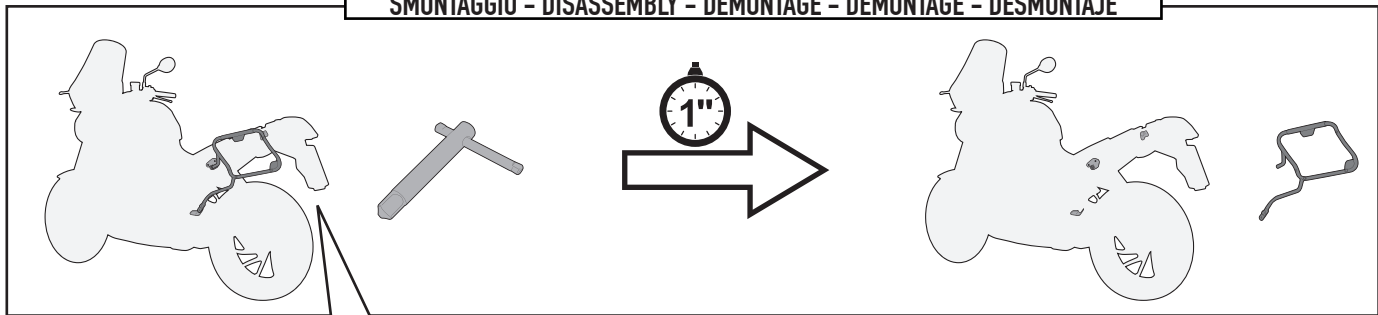

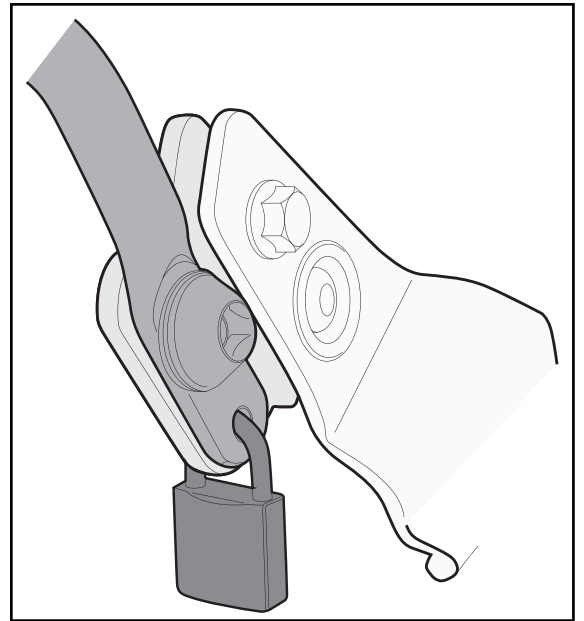
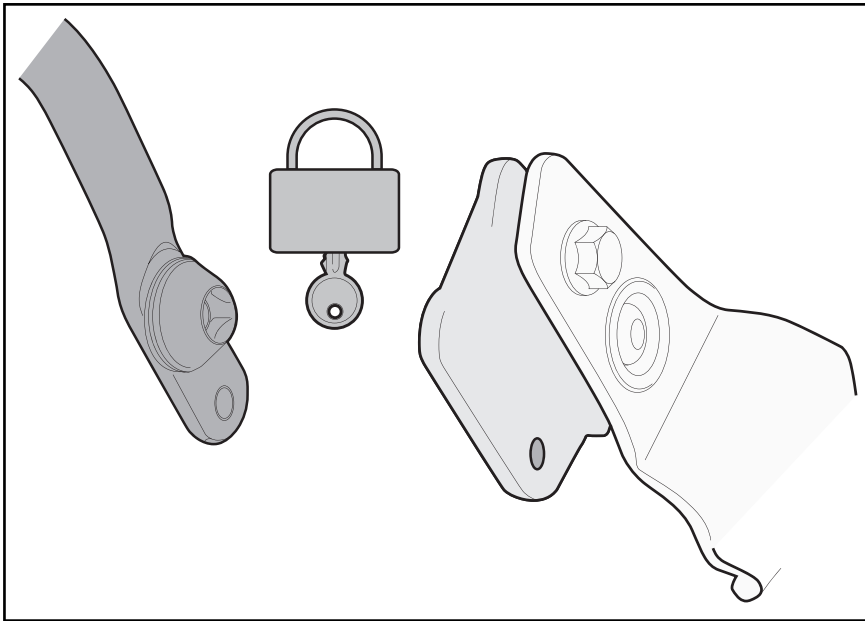
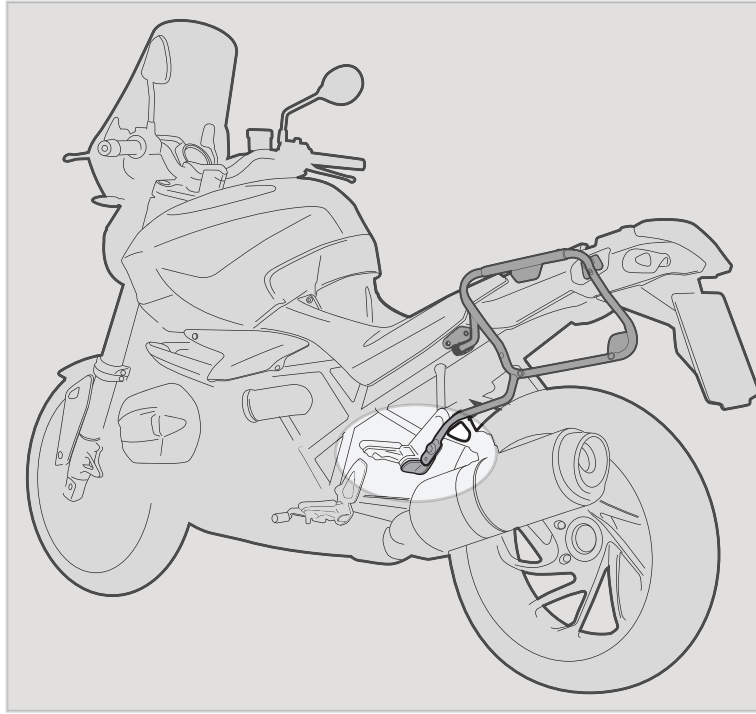

FORO DI SICUREZZA

FORO PREDISPOSTO AD ASSICURARE IL PORTAVALIGIE LATERALE ALLA MOTO (CON UN LUCCHETTO PER ESEMPIO, NON INCLUSO).

SECURITY HOLE

HOLE PLACEMENT IN ORDER TO INCREASE SECURITY OF THE TUBULAR SIDE-CASE HOLDER TO THE MOTORCYCLE (WITH A LOCK, FOR EXAMPLE, NOT INCLUDED).

TROU DE SECURITE

TROU PREDISPOSE POUR ASSURER LE PORTE-VALISE LATERAL A LA MOTO (AVEC UN CADENAS PAR EXEMPLE, NON INCLUS).

SICHERHEITSLÖCH

VORGESEHENES LOCH UM DEN SEITENKOFFER TRÄGER AN DEM FAHRZEUG ZU SICHERN (Z. B. MIT EINEM VORHÄNGESCHLOSS, NICHT ENTHALTEN);

ORIFICIO DE SEGURIDAD

ESTE ORIFICIO ESTA CREADO PARA ASEGURAR EL PORTAEQUIPAJES LATERAL A LA MOTO (POR EJEMPLO CON UN CANDADO, QUE NO ESTÁ INCLUIDO).