

PORTAVALIGIE LATERALE SPECIFICO - SPECIFIC TUBULAR SIDE-CASE HOLDER
 PORTE-VALISES LATÉRAUX SPÉCIFIQUE - SPEZIFISCHES STAHLROHR-SEITENTRÄGER
 PORTA MALETAS LATERALES ESPECIFICO

HONDA VFR800 '02/'06 VTEC

ISTRUZIONI DI MONTAGGIO - MOUNTING INSTRUCTIONS
 INSTRUCTIONS DE MONTAGE - BAUANLEITUNG - INSTRUCCIONES DE MONTAJE

1



SUPPORTO
 SUPPORT
 SUPPORT
 HALTERUNG
 SOPORTE

Q.TY n.2(Dx-Sx)

2

SUPPORTO
 SUPPORT
 SUPPORT
 HALTERUNG
 SOPORTE

Q.TY n.1

3



DISTANZIALE Ø18x14mm
 Ribassato Ø13x9mm
 foro Ø8,5mm V526

SPACER
 ENTRETOISE
 DISTANZSTUECK
 DISTANCIADOR

Q.TY n. 2

4



VITE TE M8x160mm
 SCREW M8x160mm
 VIS M8x160mm
 SCHRAUBE M8x160mm
 TORNILLO M8x160mm

Q.TY n.2

5



DISTANZIALE Ø18x12,5mm
 Ribassato Ø9,5x11,5mm
 foro Ø6,5mm V463

SPACER
 ENTRETOISE
 DISTANZSTUECK
 DISTANCIADOR

Q.TY n. 2

6



DISTANZIALE Ø12x4mm
 Foro Ø6,5mm, V222

SPACER
 ENTRETOISE
 DISTANZSTUECK
 DISTANCIADOR

Q.TY n.2

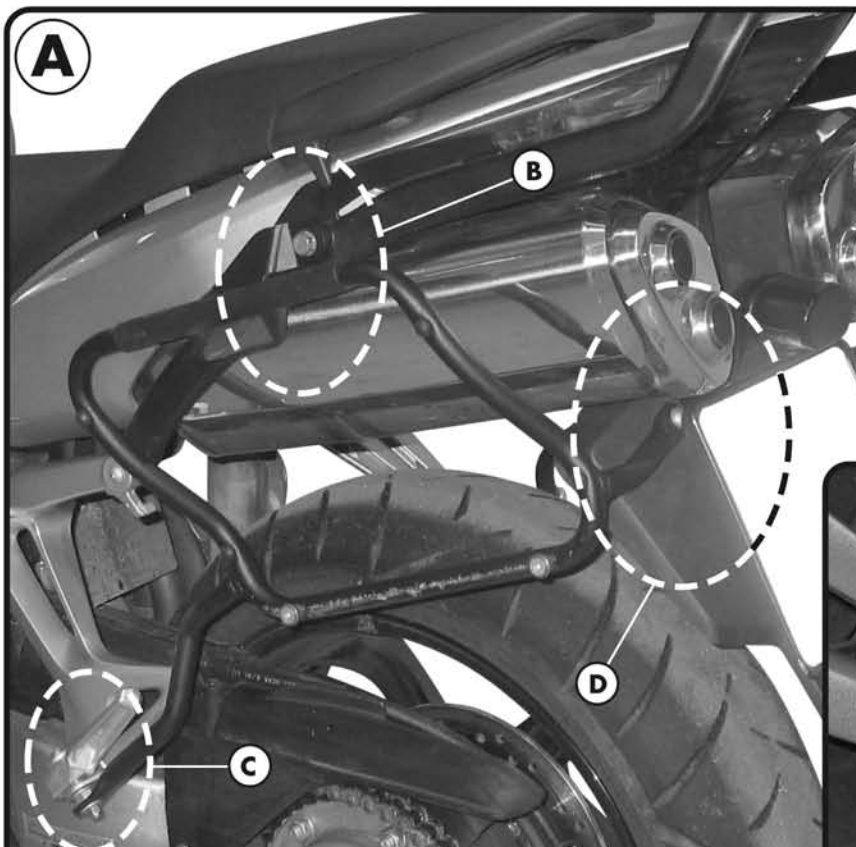

7



DISTANZIALE Ø18x95mm
 Foro Ø8,5mm, Fresato
 V455

SPACER
 ENTRETOISE
 DISTANZSTUECK
 DISTANCIADOR

Q.TY n.2

8



VITE TE M8x16mm
 SCREW M8x16mm
 VIS M8x16mm
 SCHRAUBE M8x16mm
 TORNILLO M8x16mm

Q.TY n.2

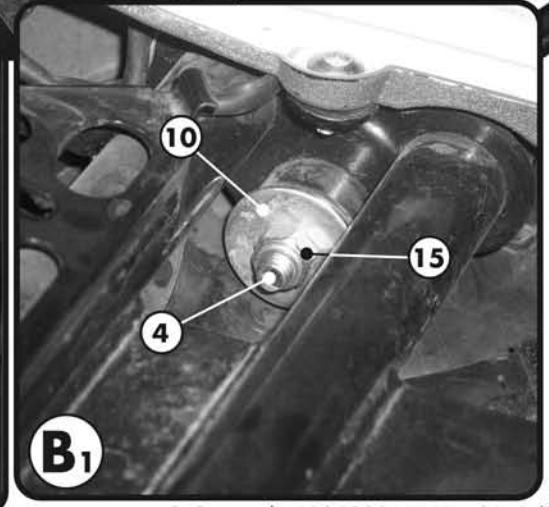
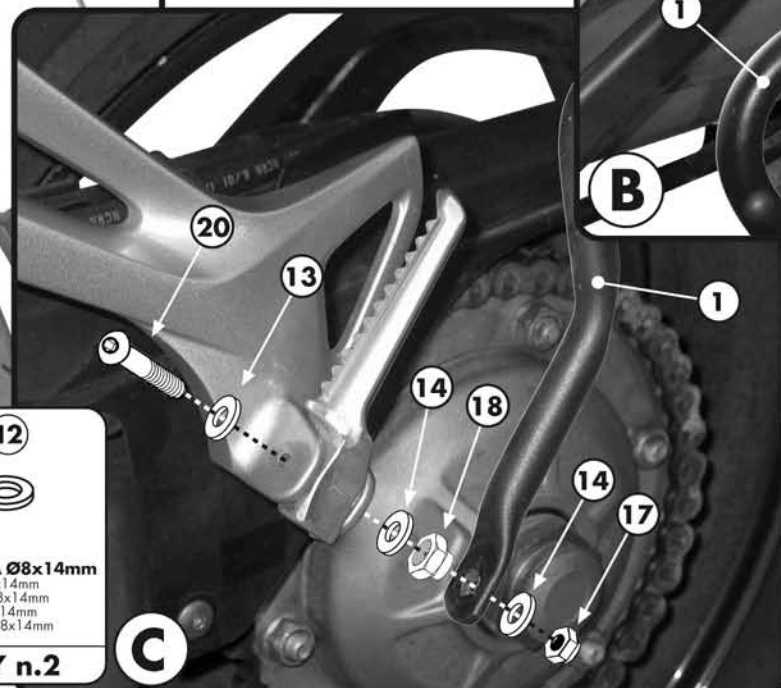
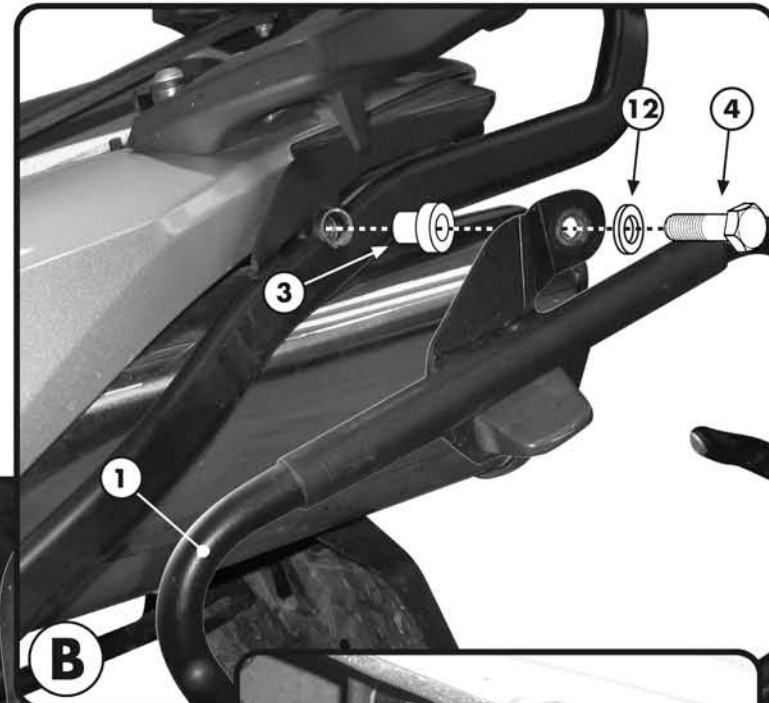

9



VITE TE M6x35mm
 SCREW M6x35mm
 VIS M6x35mm
 SCHRAUBE M6x35mm
 TORNILLO M6x35mm

Q.TY n.2

10



RONDELLA Ø32x2mm
 WASHER Ø32x2mm
 RONDELLE Ø32x2mm
 SCHEIBE Ø32x2mm
 ARANDELA Ø32x2mm

Q.TY n.2

11



RONDELLA Ø8mm
 WASHER Ø8mm
 RONDELLE Ø8mm
 SCHEIBE Ø8mm
 ARANDELA Ø8mm

Q.TY n.4

12



RONDELLA Ø8x14mm
 WASHER Ø8x14mm
 RONDELLE Ø8x14mm
 SCHEIBE Ø8x14mm
 ARANDELA Ø8x14mm

Q.TY n.2

PORTAVALIGIE LATERALE SPECIFICO - SPECIFIC TUBULAR SIDE-CASE HOLDER
 PORTE-VALISES LATÉRAUX SPÉCIFIQUE - SPEZIFISCHES STAHLROHR-SEITENTRÄGER
 PORTA MALETAS LATERALES ESPECIFICO

HONDA VFR800 '02/'06 VTEC

ISTRUZIONI DI MONTAGGIO - MOUNTING INSTRUCTIONS
 INSTRUCTIONS DE MONTAGE - BAUANLEITUNG - INSTRUCCIONES DE MONTAJE

13



RONDELLA Ø6mm
 WASHER Ø6mm
 RONDELLE Ø6mm
 SCHEIBE Ø6mm
 ARANDELA Ø6mm

Q.TY n.4

14



RONDELLA Ø6x18mm
 WASHER Ø6x18mm
 RONDELLE Ø6x18mm
 SCHEIBE Ø6x18mm
 ARANDELA Ø6x18mm

Q.TY n.4

15



DADO A.B. M8
 BOLT M8
 ECROU M8
 MUTTER M8
 TUERCA M8

Q.TY n.2

16



DADO A.B. RIB. M8
 BOLT M8
 ECROU M8
 MUTTER M8
 TUERCA M8

Q.TY n.2

17



DADO A.B. M6
 BOLT M6
 ECROU M6
 MUTTER M6
 TUERCA M6

Q.TY n.2

18



DADO SPECIALE V311
 BOLT
 ECROU
 MUTTER
 TUERCA

Q.TY n.2

19



MOUSSE PROTETTIVA Z298
 PROTECTIVE RUBBER PADS
 MOUSSE DE PROTECTION
 SCHUTZGUMMI
 ESPUMA ADHESIVA
 PROTECTORA

Q.TY n.2

20



VITE TBEI M6x55mm
 SCREW M6x55mm
 VIS M6x55mm
 SCHRAUBE M6x55mm
 TORNILLO M6x55mm

Q.TY n.2

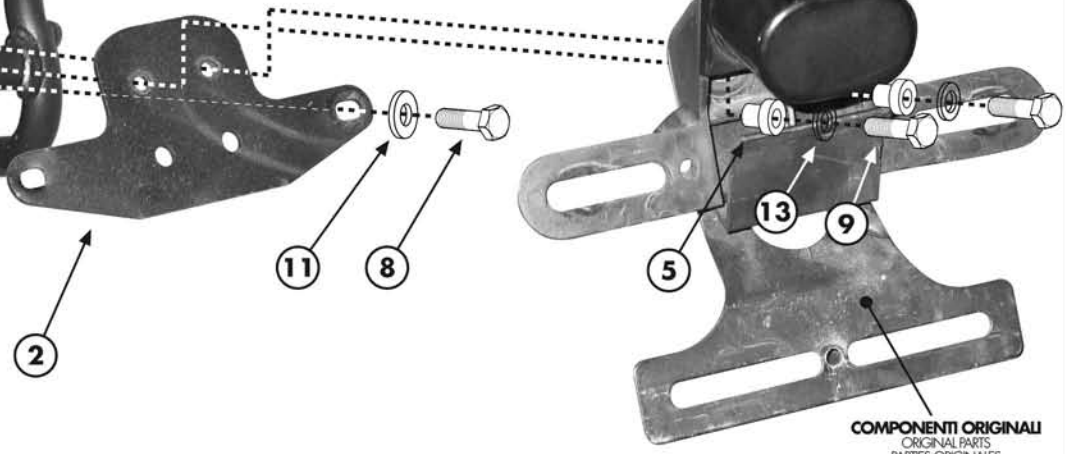
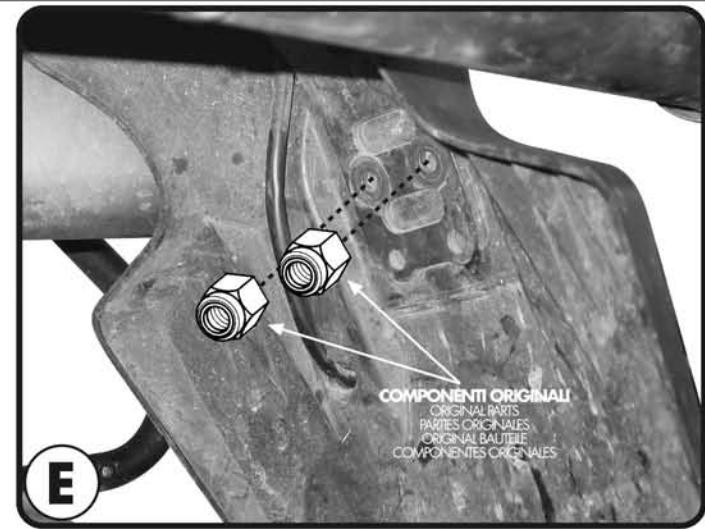
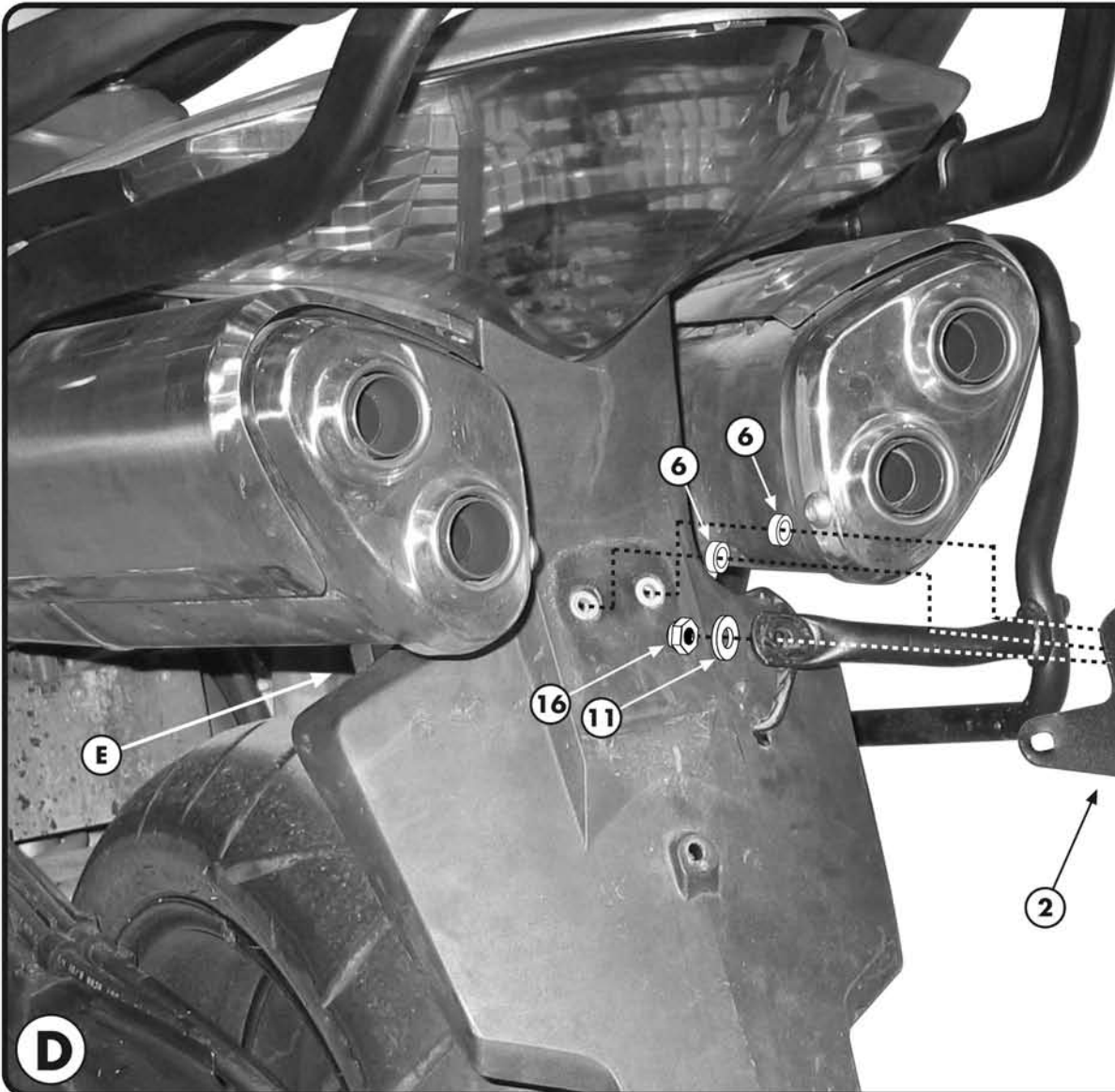

D

PORTAVALIGIE LATERALE SPECIFICO - SPECIFIC TUBULAR SIDE-CASE HOLDER
 PORTE-VALISES LATÉRAUX SPÉCIFIQUE - SPEZIFISCHES STAHLROHR-SEITENTRAEGER
 PORTA MALETAS LATERALES ESPECIFICO

HONDA VFR800 '02/'06
VTEC

ISTRUZIONI DI MONTAGGIO - MOUNTING INSTRUCTIONS
 INSTRUCTIONS DE MONTAGE - BAUANLEITUNG - INSTRUCCIONES DE MONTAJE

I ISTRUZIONI DI MONTAGGIO

1. PRIMA DI PROCEDERE NEL MONTAGGIO DEL PORTAVALIGIA LATERALE BISOGNA SMONTARE IL PORTATARGA ORIGINALE (VEDI FOTOGRAFIA D);
2. POSIZIONARE IL PORTAVALIGIA COME INDICATO IN FOTOGRAFIA B e C; NEL MONTAGGIO PROPOSTO IN FOTOGRAFIA B UTILIZZARE IL PARTICOLARE N°7 NEL CASO SI EFFETUI IL MONTAGGIO SU DI UNA MOTOCICLETTA SPROVVISTA DI PORTAVALIGIA CENTRALE MONORACK;
3. MONTARE LA PIASTRA DI SUPPORTO POSTERIORE (PARTICOLARE N°2) ED IL PORTATARGA ORIGINALE COME INICATO IN FOTOGRAFIA D;
4. ULTIMARE IL MONTAGGIO VERIFICANDO CHE TUTTE LE VITI SIANO SERRATE BENE.

GB MOUNTING INSTRUCTIONS

1. BEFORE PROCEEDING WITH THE MOUNTING OF THE SIDE-CASE HOLDER, YOU NEED TO REMOVE THE ORIGINAL NUMBER PLATE HOLDER (PICTURE D);
2. PLACE THE SIDE-CASE HOLDER AS SHOWN IN PICTURES B AND C; USE THE PART N° 7 AS SHOWN IN PICTURE B IF YOU CARRY OUT THE MOUNTING ON THE MOTORCYCLE WITHOUT THE MONORACK TOP-CASE CARRIER;
3. MOUNT THE REAR SUPPORT PLATE (PART N° 2) AND THE ORIGINAL NUMBER PLATE HOLDER AS SHOWN IN PICTURE D;
4. LASTLY CHECK THAT ALL SCREWS HAVE BEEN TIGHTENED.

F INSTRUCTIONS DE MONTAGE

1. AVANT DE PROCEDER AU MONTAGE DES SUPPORTS VALISES, IL EST NECESSAIRE DE DEMONTER LE SUPPORT DE PLAQUE MINERALOGIQUE D'ORIGINE (VOIR PHOTO D) ;
2. POSITIONNER LES SUPPORTS VALISES COMME INDIQUE EN PHOTOS B ET C ; SUR LE MONTAGE PROPOSE EN PHOTO B, UTILISER LA PIECE N°7 DANS LE CAS OU LE MONTAGE SE FAIT SUR UNE MOTO DEJA EQUIPEE DU SUPPORT TOP CASE MONORACK ;
3. MONTER LA PLATINE DE SUPPORT POSTERIEURE (PIECE N°2) PUIS LE SUPPORT PLAQUE MINERALOGIQUE COMME INDIQUE EN PHOTO D ;
4. TERMINER LE MONTAGE EN CONTROLANT LE BON SERRAGE DE TOUTES LES VIS.

D BAUANLEITUNG

1. BEVOR SIE MIT DER MONTAGE DES SEITENTRÄ'E4GERS ANFANGEN, ENTFERNEN SIE DEN ORIGINAL NUMMERNSCHILDHALTER (BILD D);..
2. POSITIONIEREN SIE DEN SEITENTRÄ'E4GERS WIE IN DEN BILDERN B UND C BESCHRIEBEN; BEI DER MONTAGE VOM BILD B VERWENDEN SIE DAS TEIL NR. 7 FALLS SIE DIE MONTAGE OHNE MONORACK TOPCASETRÄ'E4GER DURCHFU'FCHREN WOLLEN;
3. MONTIEREN SIE DIE HALTEPLATTE (TEIL NR. 2) UND DEN ORIGINAL NUMMERNSCHILDHALTER WIE IM BILD D BESCHRIEBEN;
4. ZULETZT U'FCBERPRÜ'FCFEN SIE, DASS ALLE SCHRAUBEN FESTGEZOGEN WURDEN.

ES

INSTRUCCIONES DE MONTAJE

1. ANTES DE INICIAR EL MONTAJE DEL PORTAEQUIPAJES LATERAL, DESMONTAR LA MATRÍCULA ORIGINAL (VER FOTOGRAFÍA D).
2. POSICIONAR EL PORTAEQUIPAJES TAL Y COMO SE INDICA EN LA FOTOGRAFÍA B Y C. EN EL MONTAJE PROPUESTO EN LA FOTOGRAFÍA B, UTILIZAR LA PIEZA NÚMERO 7 EN EL CASO DE QUE SE EFECTUE EL MONTAJE EN UNA MOTOCICLETA DESPROVISTA DE PORTAEQUIPAJES TRASERO SISTEMA MONORACK.
3. MONTAR LA PARRILLA UTILIZANDO LA PIEZA N°2 Y EL PORTAMATRÍCULAS ORIGINAL, TAL Y COMO SE MUESTRA EN LA FOTOGRAFÍA D.
4. ULTIMAR EL MONTAJE VERIFICANDO QUE TODOS LOS TORNILLOS ESTÉN BIEN SUJETOS.