

SR2168 - KR2168

PORTAPACCO SPECIFICO - SPECIFIC HOLDER - PORTE-PAQUET SPÉCIFIQUE - SPEZIFISCHER TRÄGER - PORTA-EQUIPAJE ESPECÍFICO - TRANSPORTADOR ESPECÍFICO

N°	Descrizione/Description	Caratteristiche/Features	Codice/Code	Quantità/Quantity
1	Supporto laterale - Lateral support - Untere Halterung Support latéral - Soporte lateral - Suporte lateral	-	SR2168DXV SR2168SXV	2(Right; Left)
2	Supporto anteriore - Front support - Support avant Vordere Unterstützung - Soporte frontal - Suporte frontal	-	GL5942DXV GL5942SXV	2(Right; Left)
3	Supporto posteriore - Rear support - Hintere Unterstützung Support arrière - Soporte trasero - Suporte traseiro	-	GL5943DXV GL5943DXV	2(Right; Left)
4	Piastra di supporto - Support plate - Plaque de support - Trägerplatte Pletina de soporte - Placa de apoio	-	GL5944V	1
5	Supporto superiore - Support higher - Support supérieur Halterung höher - Soporte superior - Apoio superior	-	GL5945SXV GL5945DXV	2(Right; Left)
6	Vite - Screw - Vis - Schraube Tornillo - Parafuso	M6x45 TBEI	645TBEI	2
7	Vite - Screw - Vis - Schraube Tornillo - Parafuso	M6x30 TSP	630TSP	4
8	Vite - Screw - Vis - Schraube Tornillo - Parafuso	M8x30 TBEIFH	830TBEIFH	10
9	Rondella - Washer - Rondelle - Scheibe Arandela - Arruela	Foro Ø6mm / Esterno Ø18mm	618RON	4
10	Distanziale - Spacer - Entretoise Distanzstueck - Distanciador - Espaçador	Ø16x25 Foro 8,5mm	C16L25F8,5T	2
11	Distanziale - Spacer - Entretoise Distanzstueck - Distanciador - Espaçador	Ø10x4 Foro 6mm	C10L4F6T	2
12	Distanziale - Spacer - Entretoise Distanzstueck - Distanciador - Espaçador	Ø18x8,5 Foro 8,5mm	C18L8,5F8,5T	4
13	Distanziale - Spacer - Entretoise Distanzstueck - Distanciador - Espaçador	Ø12x12 Foro 8,5mm	C12L12F8,5T	10
14	Dado - Bolt - Erou Mutter - Tuerca - Porca	Dado Autobloccante Flangiato M8 (H9,5mm)	8DADIFN	10
15	Tappo - Cap - Fiche - Stecker Enchufe - Capa	-	13COP	10
16	MOUSSE	5x15x170mm	MOUSSE4	1
17	Componenti Originali - Original Parts Parties Originales - Original Bauteile Componentes Originales - Componentes Originais	-	-	-
18	Particolari Inclusi Nel Kit Viteria Della Piastra Components Included In The Fitting Kit Of The Plate Pièces Incluses Dans Le Kit De Vis De La Platine Die Einzelnen Teile Sind Bei Montagekit Der Platte Enthalten Despieces Incluidos En El Kit De Anclajes De La Parrilla Explodiu Incluído No Kit As Âncoras Da Grelha	-	-	-

IT_ Nel caso in cui sulle viti originali sia presente del frenafilletti, ripristinarlo durante il montaggio dell'accessorio.

EN_ If there is threadlocker on the original screws, use threadlocker when mounting the accessory.

DE_ Falls sich auf den Originalschrauben Schraubensicherungsstoff befand, sollte dieser auch bei der Montage des Zubehörs wieder aufgetragen werden

FR_ Si du frein filet est présent sur les vis d'origine, l'appliquer également lors du montage de l'accessoire

ES_ En caso de que el fijador de roscas se encuentre presente en los tornillos originales, colocarlo nuevamente en el montaje del accesorio

PT_ Se houver trava rosca nos parafusos originais, inserir novamente durante a montagem do acessório

SR2168 - KR2168

PORTAPACCO SPECIFICO - SPECIFIC HOLDER - PORTE-PAQUET SPÉCIFIQUE - SPEZIFISCHER TRÄGER - PORTA-EQUIPAJE ESPECÍFICO - TRANSPORTADOR ESPECÍFICO

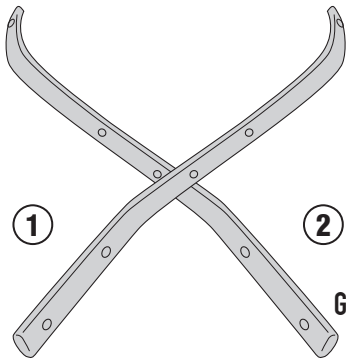

1

SR2168DXV/SR2168SXV

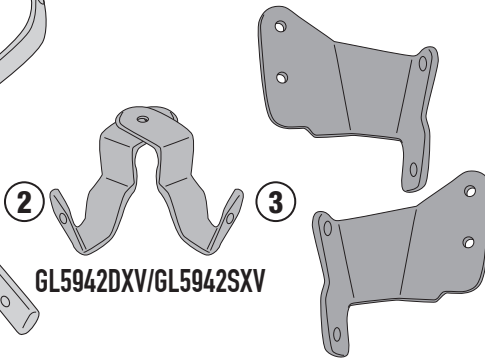

2

GL5942DXV/GL5942SXV

3

GL5943DXV/GL5943SXV

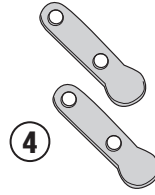

4

GL5944V

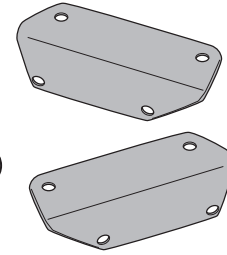

5

GL5945DXV/GL5945SXV

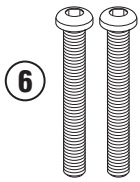

6

M6x45mm

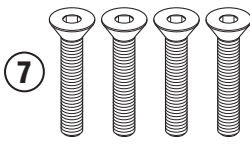

7

M6x30mm

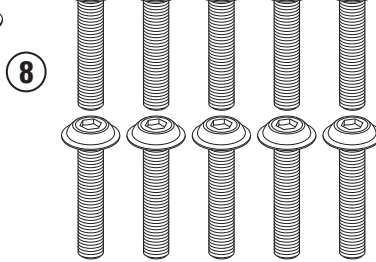

8

M8x30mm



9

Hole Ø6mm/
External Ø18mm/



10

Hole Ø8,5mm/
External Ø16mm/
H.25mm



11

Hole Ø6mm/
External Ø10mm/
H.4mm

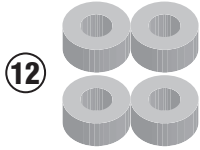

12

Hole Ø8,5mm/
External Ø18mm/
H.8,5mm

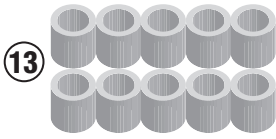

13

Hole Ø8,5mm/
External Ø12mm/
H.12mm

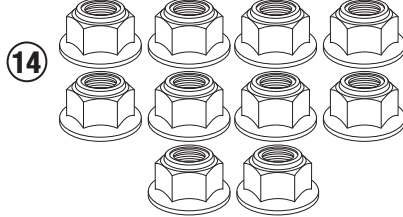

14

M8

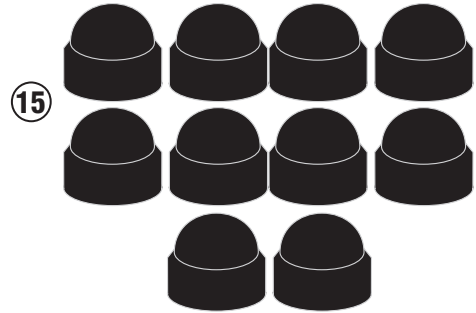

15

13COP



16

MOUSSE4



CHECK THE SCREW LENGTH HERE

mm

SR2168 - KR2168

PORTAPACCO SPECIFICO - SPECIFIC HOLDER - PORTE-PAQUET SPÉCIFIQUE - SPEZIFISCHER TRÄGER - PORTA-EQUIPAJE ESPECÍFICO - TRANSPORTADOR ESPECÍFICO

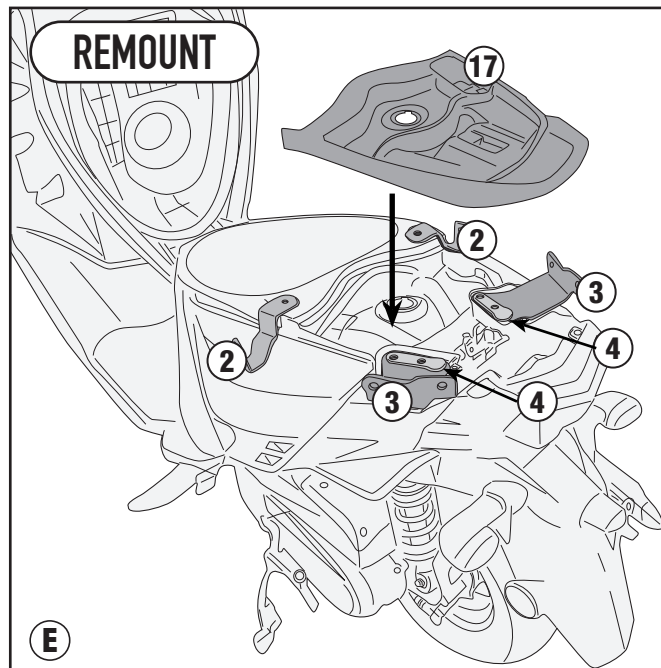
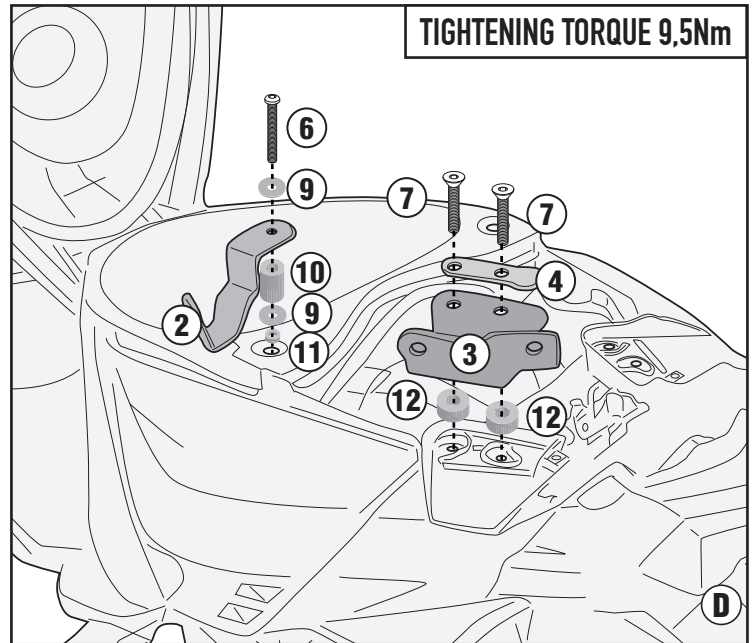
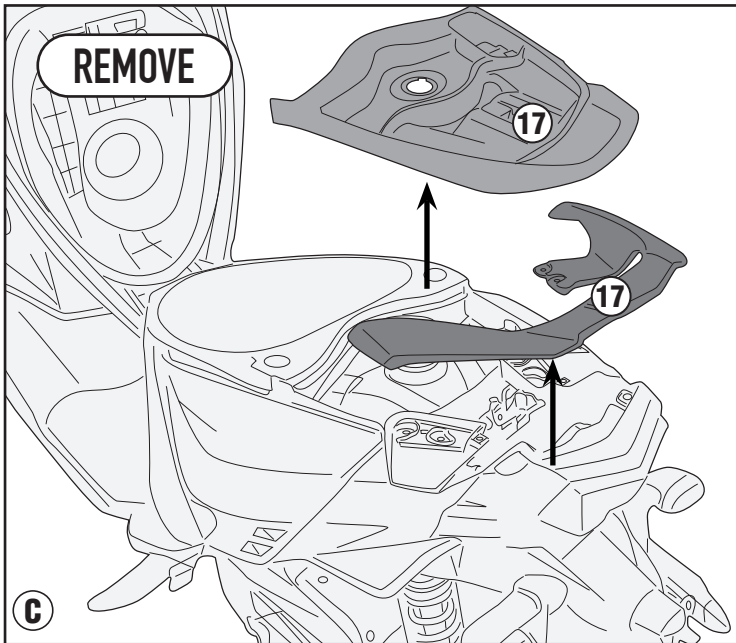
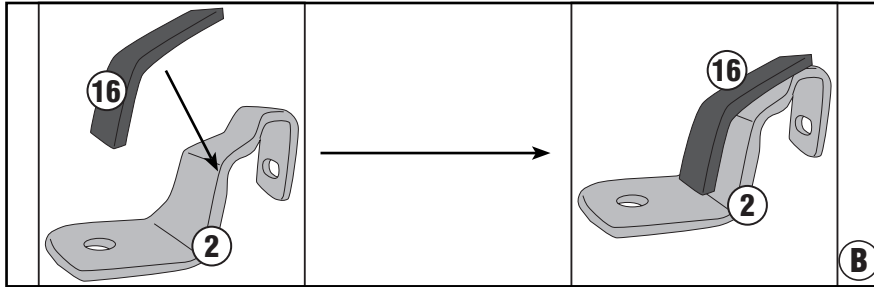
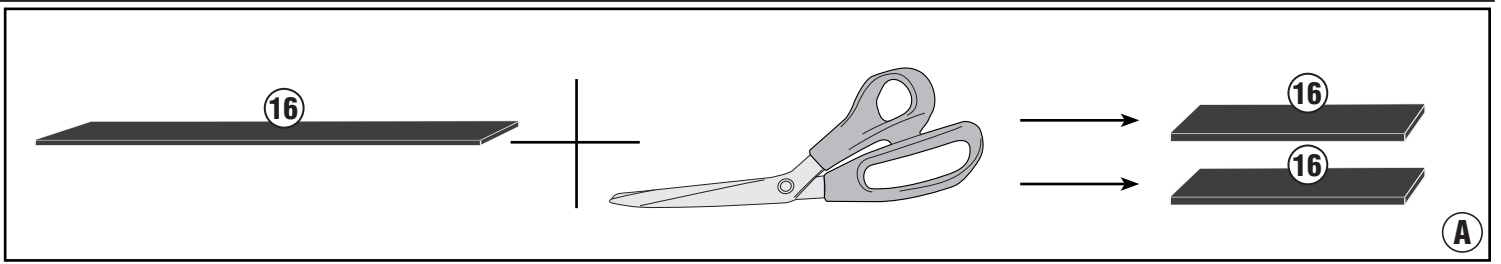

SR2168 - KR2168

PORTAPACCO SPECIFICO - SPECIFIC HOLDER - PORTE-PAQUET SPÉCIFIQUE - SPEZIFISCHER TRÄGER - PORTA-EQUIPAJE ESPECÍFICO - TRANSPORTADOR ESPECÍFICO

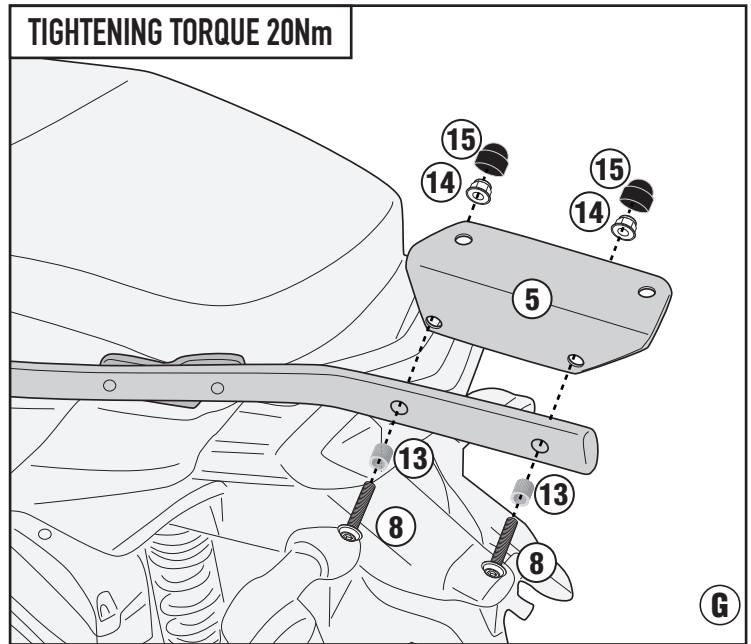
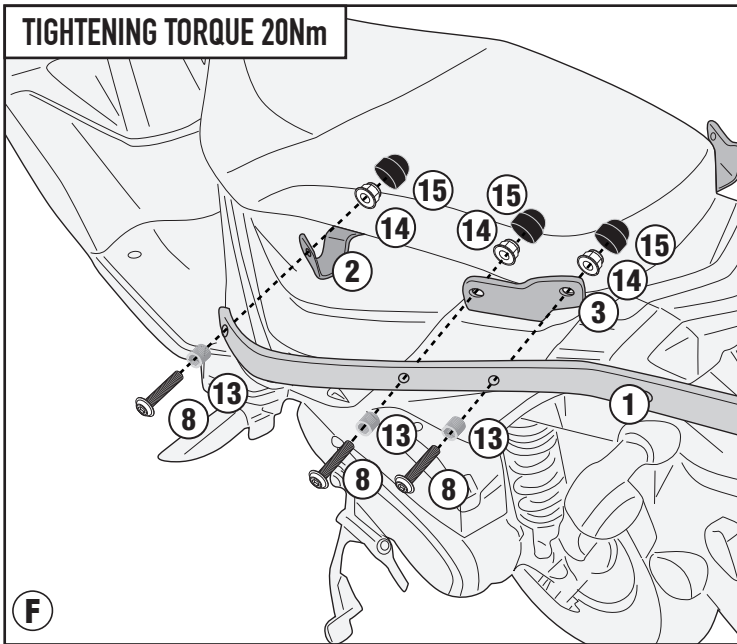

ITA - Attenzione: Serrando le viti N°8 il supporto tubolare N°1 si dovrà deformare leggermente.
 ENG - Attention: By tightening screws N°8 the tubular support N°1 will have to deform slightly.
 DEU - Achtung: Beim Anziehen der Schrauben Nr 8 sollte sich die Rohrhalterung Nr. 1 leicht verformen.
 FRA - Attention: En serrant les vis N°8 le support tubulaire N°1 devra se déformer légèrement.
 SPA - Atención: Apretando los tornillos N°8 el soporte tubular N°1 deberá deformarse ligeramente.
 POR - Atenção: Ao apertar os parafusos N°8 o suporte tubular N°1 terá de se deformar ligeiramente.

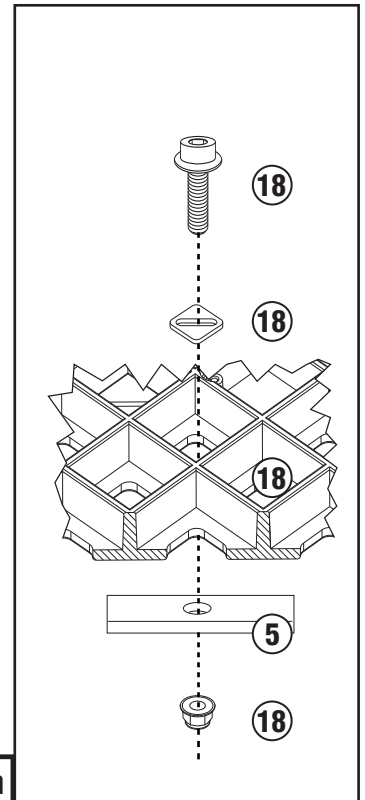
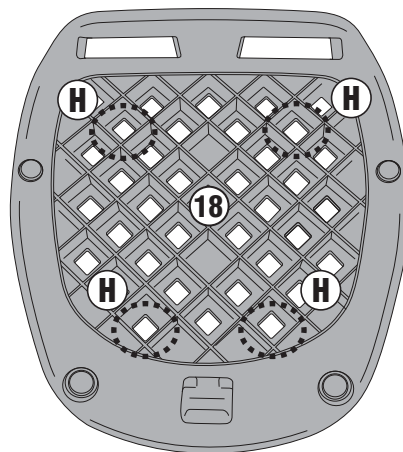
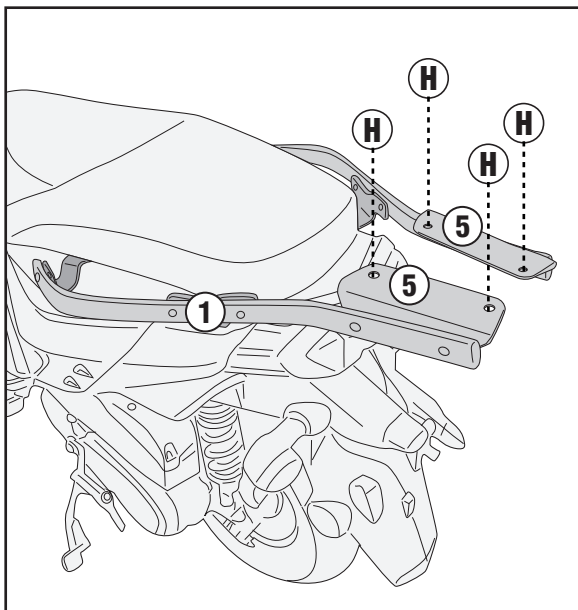

TIGHTENING TORQUE 7,5Nm