

SR2178 – KR2178

MONORACK SPECIFICO – SPECIFIC MONORACK – MONORACK SPECIFIQUE – SPEZIFISCHES MONORACK – MONORACK ESPECÍFICO – MONORACK ESPECÍFICA

N°	Descrizione/Description	Caratteristiche/Features	Codice/Code	Quantità/Quantity
1	Supporto superiore – Support higher – Support supérieur Halterung höher – Soporte superior – Apoio superior	-	GL6598V	1
2	Cavalotto – Retaining clamp – Patte de fixation – Abrazadera Halteklammern – Abraçadeira de fixação	-	GL2377GOM	4
3	Vite – Screw – Vis – Schraube Tornillo – Parafuso	M6x20 TSP	620TSP	2
4	Vite – Screw – Vis – Schraube Tornillo – Parafuso	M6x20 TBEI	620TBEI	2
5	Vite – Screw – Vis – Schraube Tornillo – Parafuso	M6x20 TBEIFN	620TBEIFN	4
6	Rondella – Washer – Rondelle – Scheibe Arandela – Arruela	Foro Ø6mm/ Esterno Ø20mm Sp.2mm	620RON	6
7	Distanziale – Spacer Entretoise – Distanzstueck Distanciador – Espaçador	Ø20x3 Foro 6mm	C20L3F6T	2
8	Dado – Bolt – Ecrou Mutter – Tuerca – Porca	Dado Autobloccante Flangiato Basso M6 (H.7mm)	6DADIABFN	4
9	Dado a gabbia – Cage nut Écrou cage – Tuerca jaula Halterung für Mutter – Porca especial	M6	6DADIGB	4
10	Particolari Inclusi Nel Kit Viteria Della Piastra Components Included In The Fitting Kit Of The Plate Pièces Inclues Dans Le Kit De Vis De La Platine Die Einzelnen Teile Sind Bei Montagekit Der Platte Enthalten Despieces Incluidos En El Kit De Anclajes De La Parrilla Explodiu Incluído No Kit As Âncoras Da Grelha	-	-	-

- ATTENZIONE : STRINGERE LE VITI SOLO DOPO AVER ULTIMATO IL CORRETTO POSIZIONAMENTO DEI COMPONENTI
- CAUTION : TIGHTEN THE SCREW ONLY AFTER COMPONENTS HAVE BEEN PLACED IN THEIR CORRECT POSITIONS.
- ATTENTION : SERRER LES VIS QUE LORSQUE LES COMPOSANTS ONT ÉTÉ MISES EN POSITION CORRECTE.
- ACHTUNG : SCHRAUBE ERST DANN ANZUZIEHEN, WENN DIE KOMPONENTEN POSITIONIERT SIND.
- ATENCIÓN : APRETAR LOS TORNILLOS SOLO DESPUES DE HABER ULTIMADO EL CORRECTO POSICIONAMIENTO DE LOS COMPONENTES.
- CUIDADO : APERTAR O PARAFUSO SOMENTE DEPOIS QUE COMPONENTES FORAM COLOCADOS NAS POSIÇÕES CORRETAS.

IT_ Nel caso in cui sulle viti originali sia presente del frenafilletti, ripristinarlo durante il montaggio dell' accessorio.

EN_ If there is threadlocker on the original screws, use threadlocker when mounting the accessory.

DE_ Falls sich auf den Originalschrauben Schraubensicherungsstoff befand, sollte dieser auch bei der Montage des Zubehörs wieder aufgetragen werden

FR_ Si du frein filet est présent sur les vis d'origine, l'appliquer également lors du montage de l'accessoire

ES_ En caso de que el fijador de roscas se encuentre presente en los tornillos originales, colocarlo nuevamente en el montaje del accesorio

PT_ Se houver trava rosca nos parafusos originais, inserir novamente durante a montagem do acessório

SR2178 - KR2178

MONORACK SPECIFICO - SPECIFIC MONORACK - MONORACK SPECIFIQUE - SPEZIFISCHES MONORACK - MONORACK ESPECÍFICO - MONORACK ESPECÍFICA

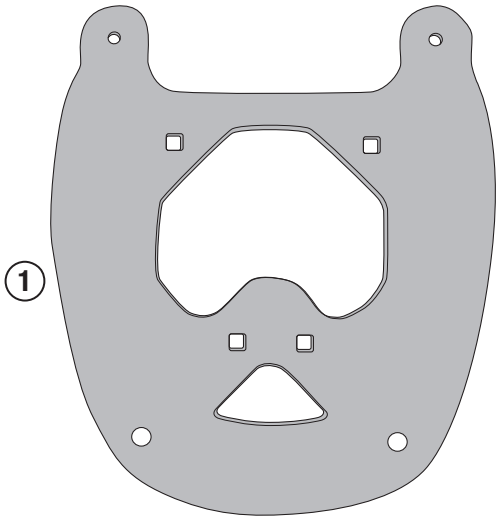

GL6598V

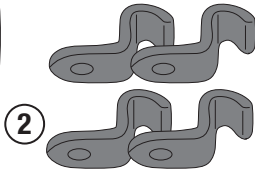

GL2377G0M

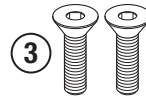

M6x20mm

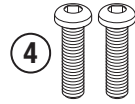

M6x20mm

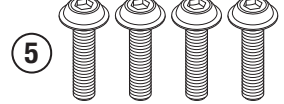

M6x20mm

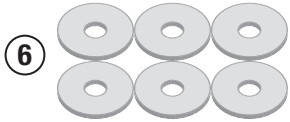

Hole Ø6mm/
External Ø20mm/
Th.2mm



Hole Ø6mm/
External Ø20mm/
H.3mm



M6



M6

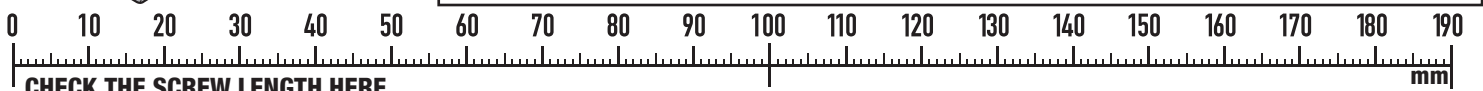
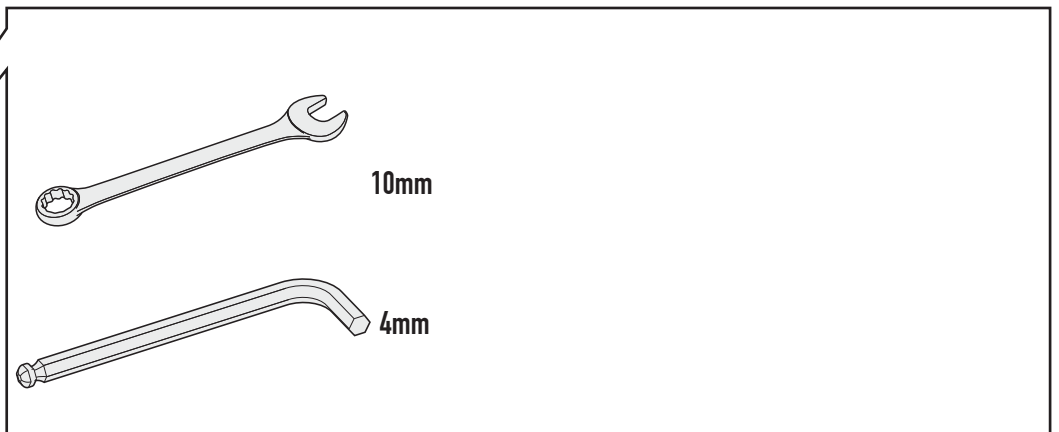
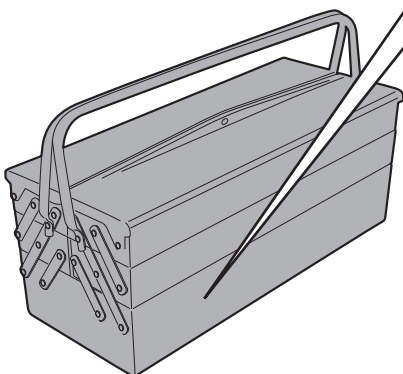

CHECK THE SCREW LENGTH HERE

ISTRUZIONI DI MONTAGGIO - MOUNTING INSTRUCTIONS
INSTRUCTIONS DE MONTAGE - BAUANLEITUNG
INSTRUCCIONES DE MONTAJE - INSTRUÇÕES DE MONTAGEM

SR2178 - KR2178

MONORACK SPECIFICO - SPECIFIC MONORACK - MONORACK SPECIFIQUE - SPEZIFISCHES MONORACK - MONORACK ESPECÍFICO - MONORACK ESPECÍFICA

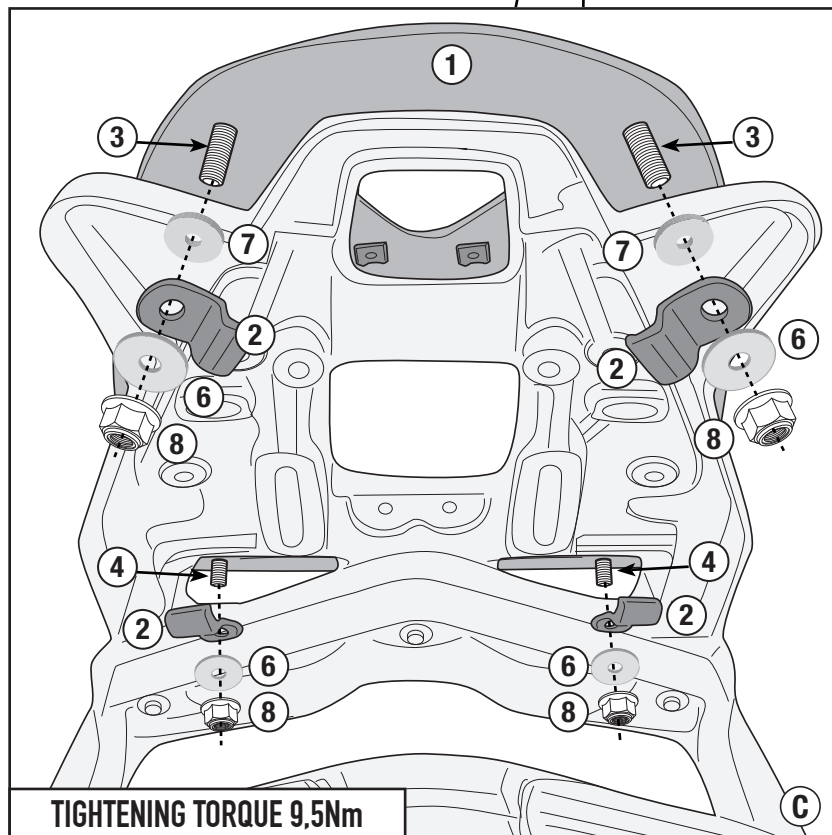
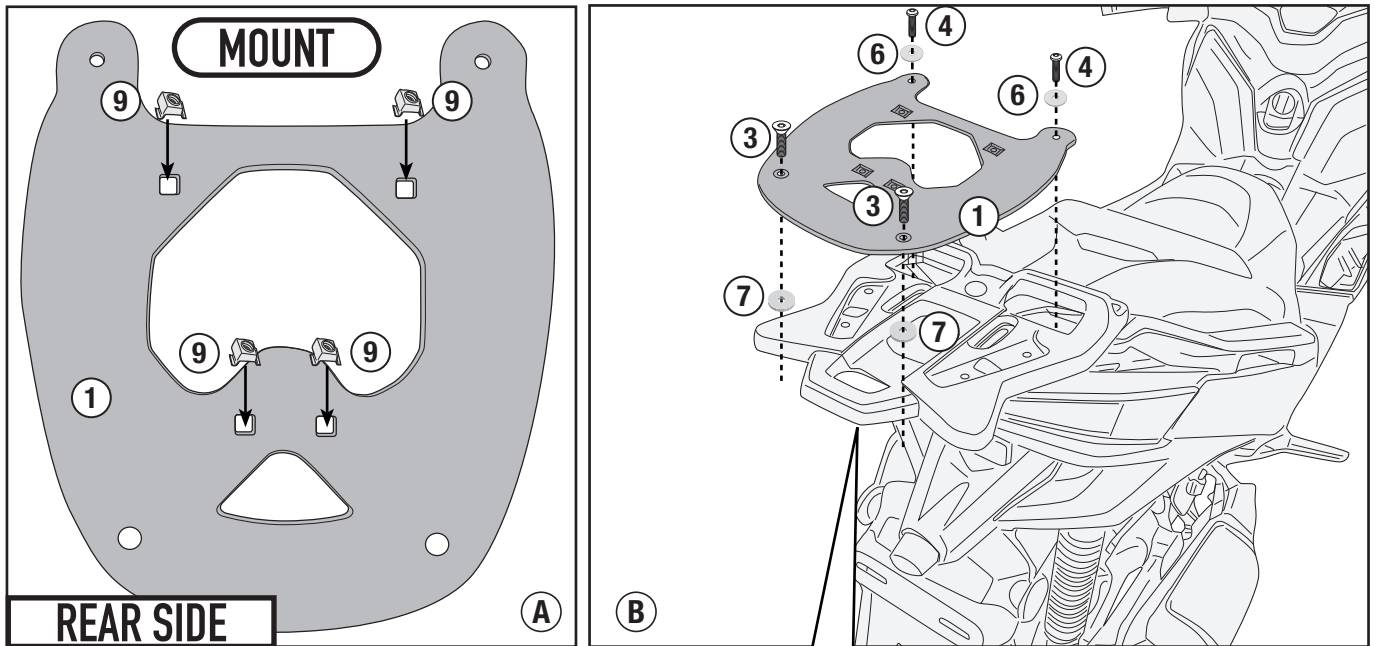

SR2178 - KR2178

MONORACK SPECIFICO - SPECIFIC MONORACK - MONORACK SPECIFIQUE - SPEZIFISCHES MONORACK - MONORACK ESPECÍFICO - MONORACK ESPECÍFICA

UNIVERSAL MONOLOCK PLATE (PART NUMBER Z113C2)

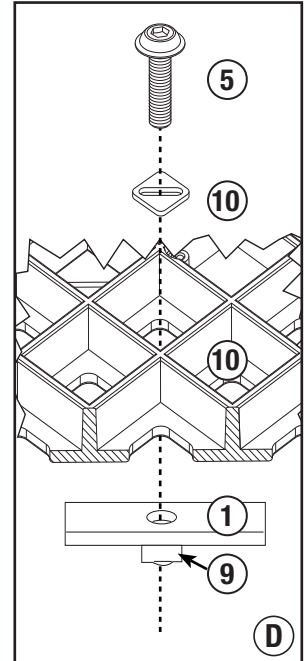
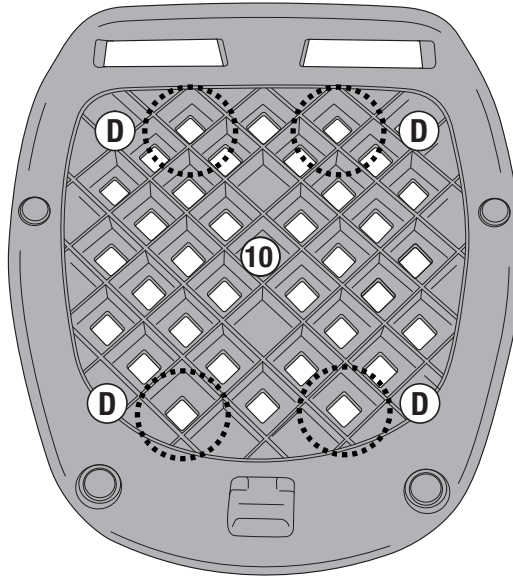
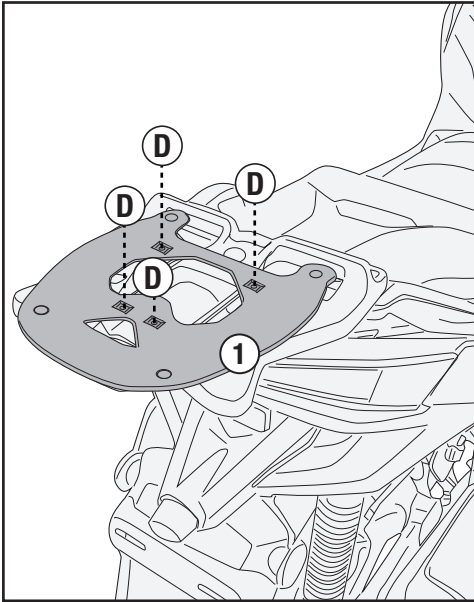

TIGHTENING TORQUE 9,5Nm