

PORTAVALIGIA SPECIFICO - SPECIFIC CASE HOLDER
 PORTE-VALISE SPÉCIFIQUE - SPEZIFISCHER KOFFER-TRÄGER
 PORTA-EQUIPAJE ESPECÍFICO

YAMAHA T-MAX 500cc '08

ISTRUZIONI DI MONTAGGIO - MOUNTING INSTRUCTIONS
 INSTRUCTIONS DE MONTAGE - BAUANLEITUNG - INSTRUCCIONES DE MONTAJE

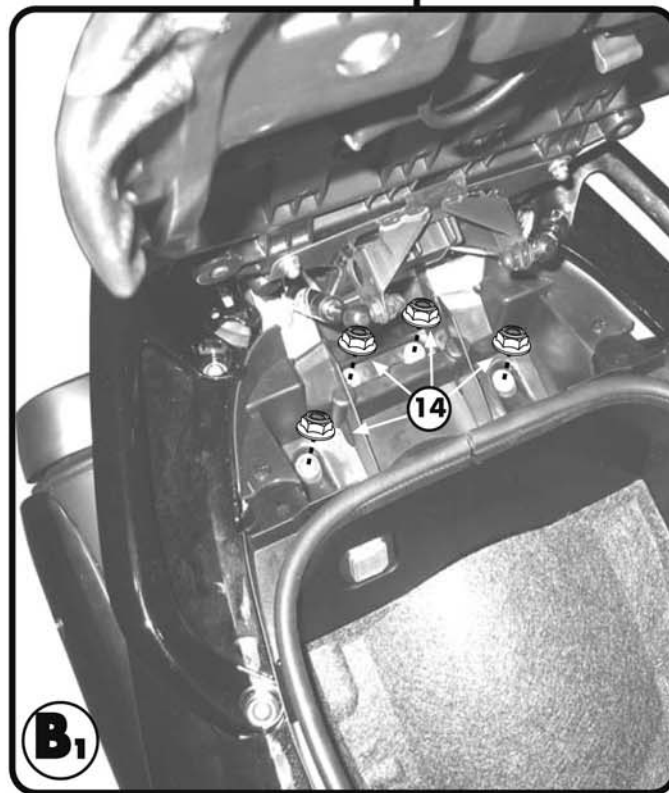
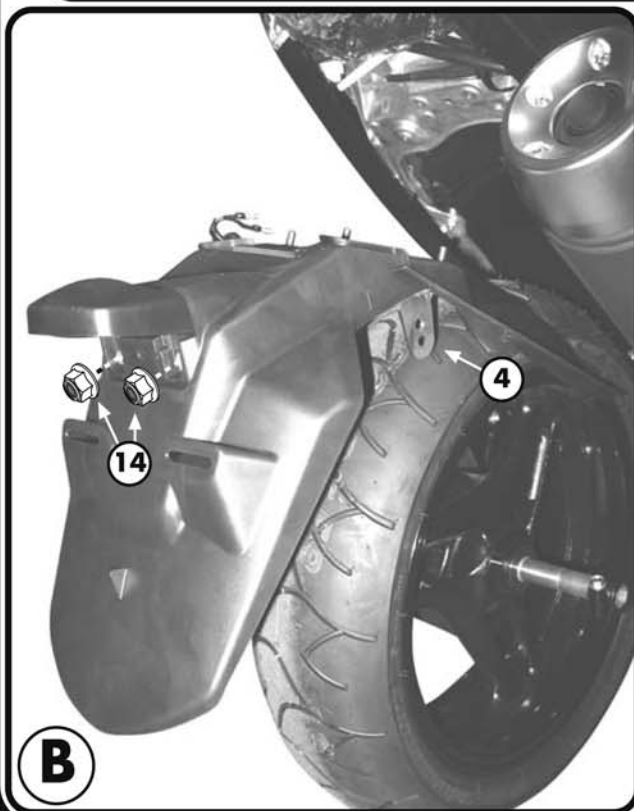
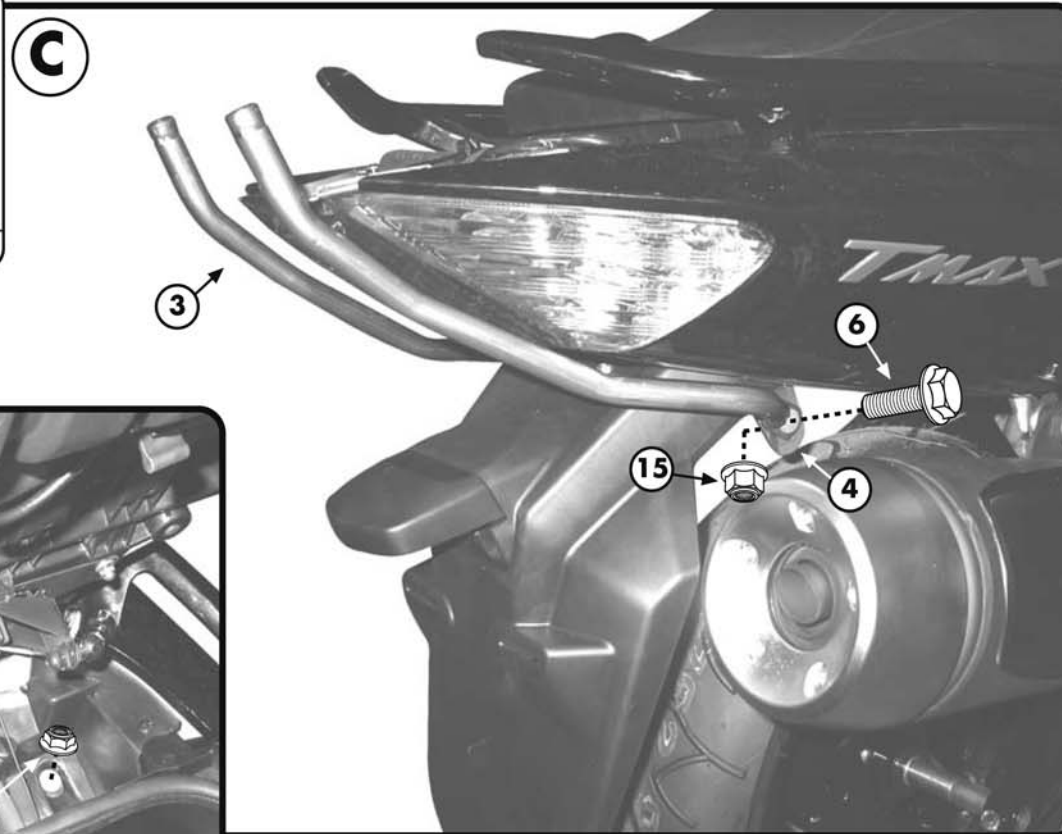
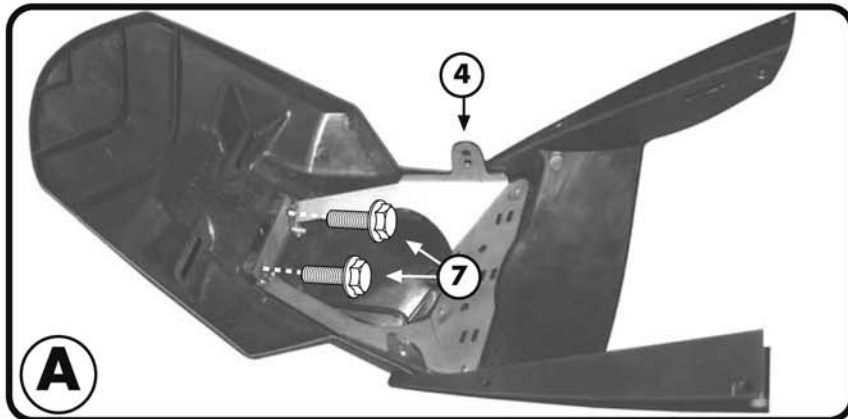

PORTAVALIGIA SPECIFICO - SPECIFIC CASE HOLDER
 PORTE-VALISE SPECIFIQUE - SPEZIFISCHER KOFFER-TRÄGER
 PORTA-EQUIPAJE ESPECÍFICO

YAMAHA T-MAX 500cc '08

ISTRUZIONI DI MONTAGGIO - MOUNTING INSTRUCTIONS
 INSTRUCTIONS DE MONTAGE - BAUANLEITUNG - INSTRUCCIONES DE MONTAJE

12



DISTANZIALE Ø14x16mm
 Foro Ø8,5mm, V457
 SPACER
 ENTRETROISE
 DISTANZSTUECK
 DISTANCIADOR

Q.TY n.1

13



DISTANZIALE Ø14x55mm
 Foro Ø8,5mm
 V685
 SPACER
 ENTRETROISE
 DISTANZSTUECK
 DISTANCIADOR

Q.TY n.2

14



DADO A.B. M6
 FLANGIATO
 BOLT M6
 ECROU M6
 MUTTER M6
 TUERCA M6

Q.TY n.10

15



DADO A.B. M8
 FLANGIATO
 BOLT M8
 ECROU M8
 MUTTER M8
 TUERCA M8

Q.TY n.2

16



COPRIFORO
 Z621
 BOLT CAP
 CACHE TROU
 STOPSLOCK
 TAPA AGUJERO

Q.TY n.6

17



GOMMINO
 Z1827
 FAIRLEADER
 CHAUMARD
 GUMMI
 GOMA

Q.TY n.3

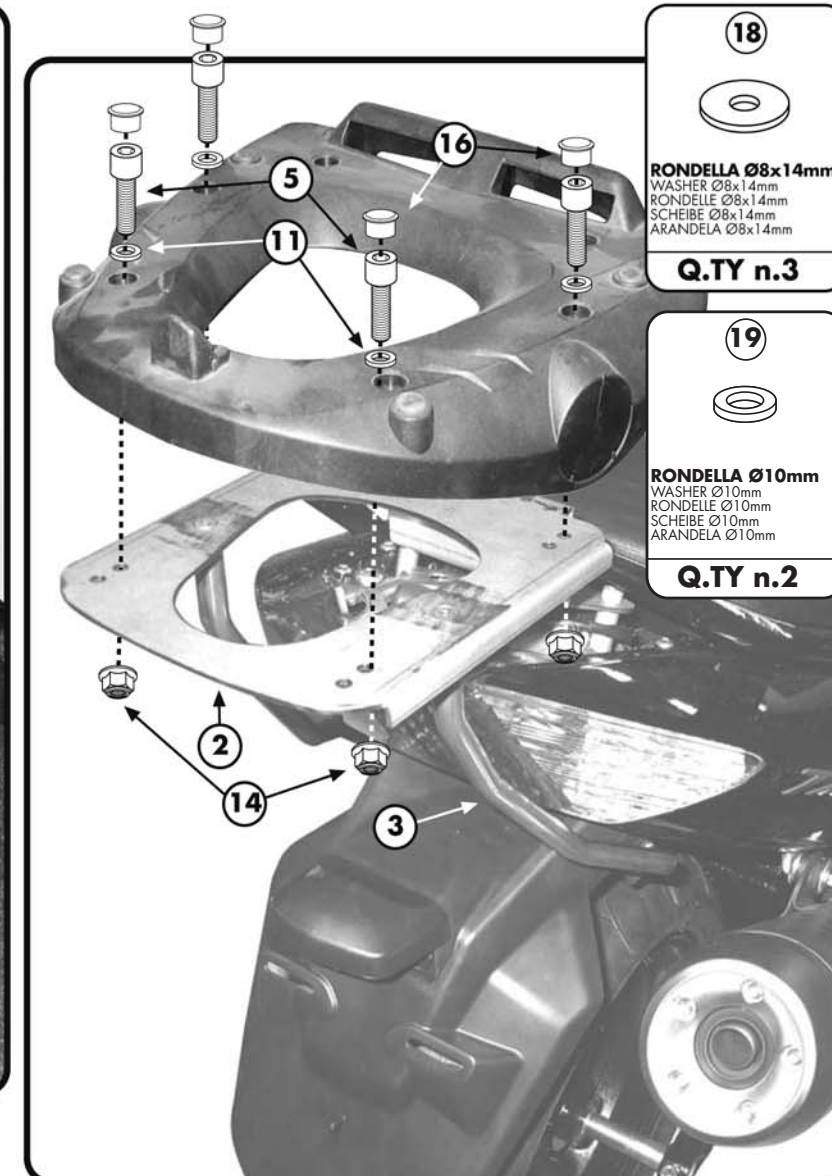
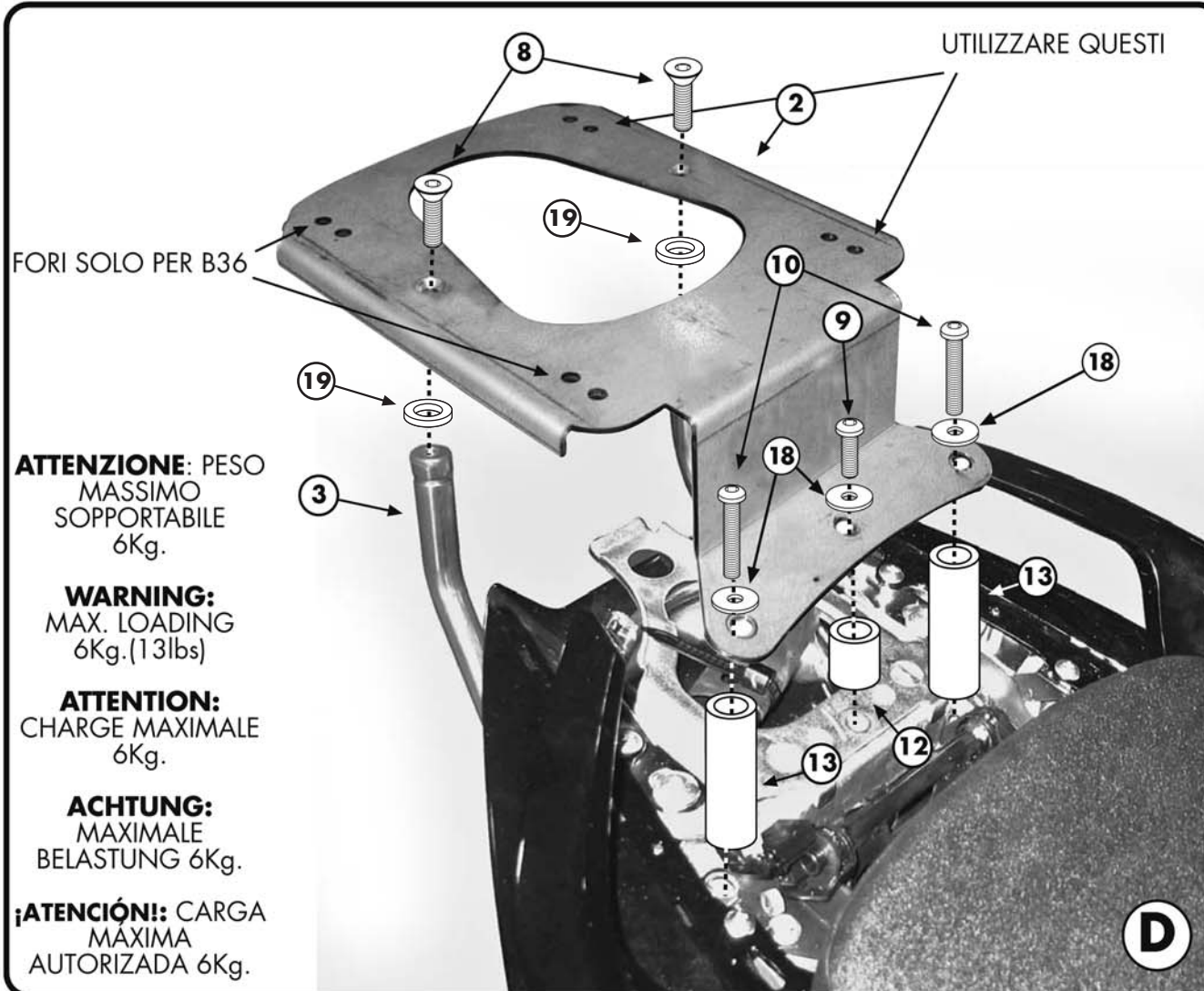

PORTAVALIGIA SPECIFICO - SPECIFIC CASE HOLDER
PORTE-VAISE SPÉCIFIQUE - SPEZIFISCHER KOFFER-TRÄGER
PORTA-EQUIPAJE ESPECIFICO

YAMAHA T-MAX 500cc '08

ISTRUZIONI DI MONTAGGIO - MOUNTING INSTRUCTIONS
INSTRUCTIONS DE MONTAGE - BAUANLEITUNG - INSTRUCCIONES DE MONTAJE

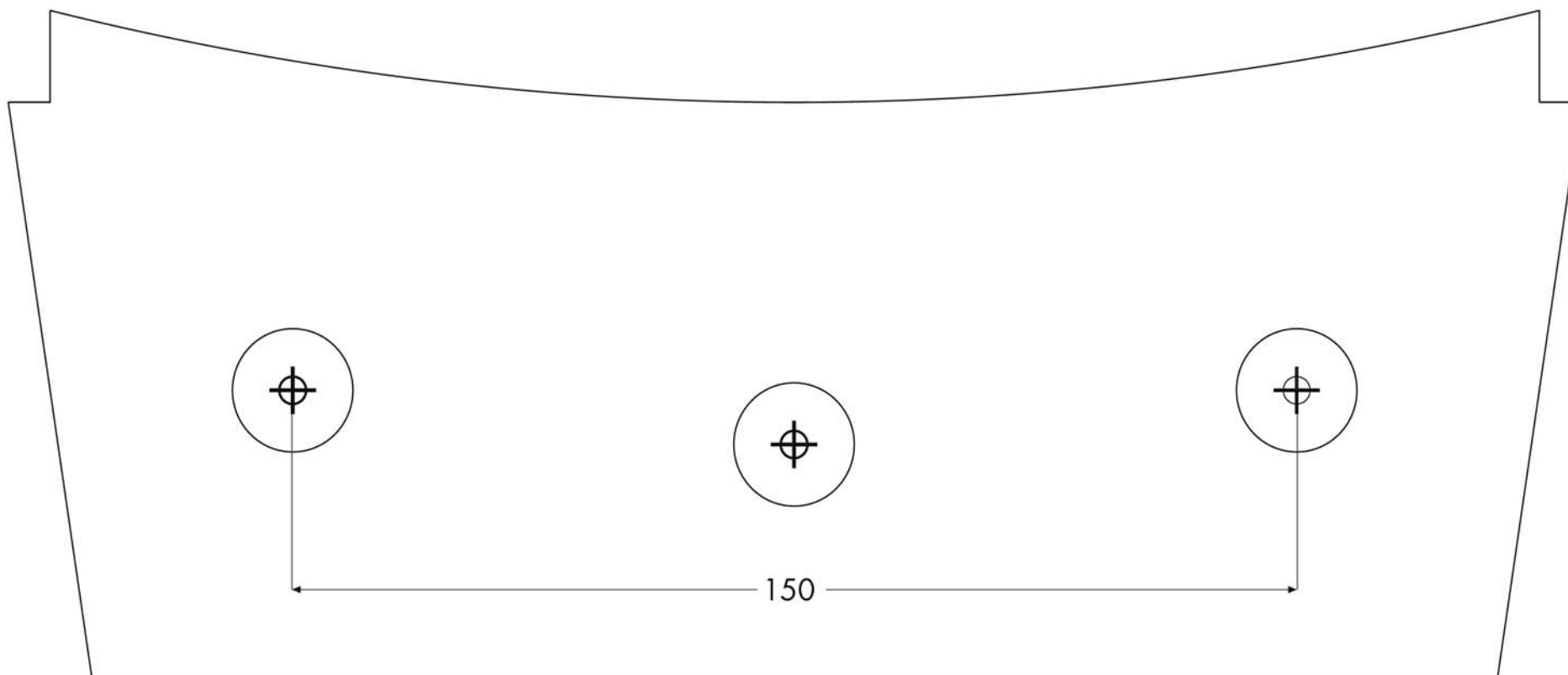

PORTAVALIGIA SPECIFICO - SPECIFIC CASE HOLDER
 PORTE-VALISE SPÉCIFIQUE - SPEZIFISCHER KOFFER-TRÄGER
 PORTA-EQUIPAJE ESPECÍFICO

YAMAHA T-MAX 500cc '08

ISTRUZIONI DI MONTAGGIO - MOUNTING INSTRUCTIONS
 INSTRUCTIONS DE MONTAGE - BAUANLEITUNG - INSTRUCCIONES DE MONTAJE

I ISTRUZIONI DI MONTAGGIO

- SMONTARE IL PORTATARGA ORIGINALE DELLO SCOOTER, RIMUOVERE IL TELAIETTO MONTATO SU QUESTO E SOSTITUIRLO CON IL SUPPORTO "4" (VEDERE FIGURE "A"-"B"). RIMONTARE IL PORTATARGA ORIGINALE COME INDICATO NELLE FIGURE "B" E "B1". SEGUIRE IL MONTAGGIO DEI I SUPPORTI "3" NELLA FIGURA "C"; SUCCESSIVAMENTE SMONTARE IL CARTERINO SUPERIORE ORIGINALE E POSIZIONARE LA DIMA DI FORATURA CHE SI TROVA NEL FOGLIO 3 (FORARE PRIMA CON UNA PUNTA PICCOLA E POI ALLARGARE I FORI FINO AL DIAMETRO DI 18mm IN MODO DA POTER METTERE I TRE PASSACAVI INDICATI CON IL PARTICOLARE "17"). MONTARE IL SUPPORTO 2 COME INDICATO IN FIGURA "D" ED INFINE LA PIASTRA MONOLOCK SEGUENDO IL MONTAGGIO PROPOSTO IN FIGURA "E".
- ULTIMARE IL MONTAGGIO VERIFICANDO CHE TUTTE LE VITI SIANO SERRATE BENE (VITI M6=9,6Nm - VITI M8=23Nm) E CHE IL TAPPO ANTIFURTO ED I GOMMINI SIANO MONTATI CORRETTAMENTE SULLA PIASTRA.

GB MOUNTING INSTRUCTIONS

- REMOVE REAR UNDER-PANEL AND REPLACE ORIGINAL REGISTRATION SUPPORT WITH ITEM "4" USING SCREWS AND NUTS (ITEMS "7" & "14") AS SHOWN IN PICTURES A & B.
- REATTACHED THE REAR UNDER-PANEL AS SHOWN IN PICTURES B & B1
- ONCE THE PANEL IS RE-INSTALLED CORRECTLY, MOUNT THE SUPPORT ARMS (ITEM "3" LEFT & RIGHT) TO REGISTRATION SUPPORT BRACKET "4" USING BOLTS AND NUTS (ITEMS 6 & 4) AS SHOWN IN PICTURE C.
- REMOVE SMALL TOP BODYWORK PANEL. CUT THE DRILLING TEMPLATE FROM PAGE 3. ALIGN TEMPLATE TO UNDERSIDE OF BODYWORK PANEL AS SHOWN IN ILLUSTRATION.
- PIERCE THE TEMPLATE WITH A SHARP POINT TO MARK THE CENTER OF THE HOLE TO BE DRILLED.
- REMOVE PAPER TEMPLATE, DRILL THROUGH THE MARK-POINT YOU JUST MADE ON THE PANEL.
- WIDEN THE HOLES TO 18MM (5/8") DIAMETER AND INSERT RUBBER GROMETS (ITEMS "17")
- CAREFULLY SET THE SPACERS (ITEMS "12" & "13") AS SHOWN IN PICTURE D. AND AFTER ALIGNING THE TOP BODYWORK PANEL AND SUPPORT BRACKET (ITEM "2") OVER THE SPACERS, DROP THE BOLTS (ITEMS "9" & "10") INTO THEIR RELEVANT HOLES
- ATTACH SUPPORT BRACKET (ITEM "2") TO SUPPORT ARMS (ITEMS "4" LEFT & RIGHT) USING BOLTS (ITEMS "8") AND TIGHTEN ALL THE BOLTS.
- ALIGN TOP PLATE (ITEM "1") ONTO SUPPORT PLATE (ITEM "2") AND ATTACH USING BOLTS, WASHERS, NUTS (ITEMS "11", "5", "16") AS SHOWN IN PICTURE E.
- MAKE SURE ALL HARDWARE AND BOLTS ARE SECURELY FASTENED. SECURELY ATTACH YOUR GIVI TRUNK, AND ENJOY YOUR RIDE.

F INSTRUCTIONS DE MONTAGE

- DEMONTÉ LE SUPPORT PLAQUE D'ORIGINE DU SCOOTER, ENLEVER LE CADRE MONTE SUR CELUI-CI ET LE REMPLACER PAR LE SUPPORT N°4 (PHOTOS A ET B) ;
- REMONTEZ LE SUPPORT PLAQUE D'ORIGINE COMME INDIQUE EN PHOTOS B ET B1 ;
- SUIVRE LE MONTAGE DES BRAS N°3 EN PHOTO C; ENSUITE DEMONTÉ LE PETIT CARTER SUPERIEUR D'ORIGINE ET POSITIONNER LE GABARIT DE PERCAGE QUI SE TROUVE SUR LA FEUILLE 3 (D'ABORD PERCER AVEC UNE PETITE MECHE ET PUIS ELARGIR LES TROUS JUSQU'A UN DIAMETRE DE 18mm DE FACON A POUVOIR METTRE LES PASSE-CABLES (PIECES N°17).
- MONTEZ LE SUPPORT 2 COMME INDIQUE EN PHOTO D ET ENFIN LA PLATINE MONOKEY EN SUIVANT LE MONTAGE PROPOSE EN PHOTO E.
- TERMINER LE MONTAGE EN CONTROLANT LE BON SERRAGE DE TOUTES LES VIS (VIS M6=9,6Nm M8=23Nm) ET QUE LE BOUCHON ANTIVOL ET LES CAOUTCHOUCS SOIENT CORRECTEMENT MONTES SUR LA PLATINE.

D BAUANLEITUNG

- DEMONTIEREN SIE DIE ORIGINAL KENNZEICHENHALTERUNG AM ROLLER, ENTFERNEN SIE DAS FAHRGESTELL UND ERSETZEN SIE DIESE MIT DEM TEIL NR. 4 (BILD A UND B)
- MONTIEREN SIE DIE ORIGINAL KENNZEICHENHALTERUNG WIEDER WIE IN DEN BILDERN B UND B1 GEZEIGT.
- FOLGEN SIE DER MONTAGE DER HALTERUNG NR. 3 WIE IM BILD C GEZEIGT. DANN ENTFERNEN SIE DAS OBERE ORIGINAL-GEHÄUSE UND POSITIONIEREN SIE DIE SCHABLONE, DIE SICH AUF DER SEITE 3 BEFINDET (BOHREN SIE ERST MIT EINEM KLEINEN BOHRER UND DANN VERBREITERN SIE DIE LÖCHER BIS ZU EINEM DURCHMESSER VON 18 MM, SO DASS MAN DIE 3 KABELDURCHGÄNGE (POSITION NR. 17) BEFESTIGEN KANN.
- MONTIEREN SIE DIE HALTERUNG NR. 2 WIE IM BILD D GEZEIGT UND DANN DIE MONOKEY PLATTE WIE IM BILD E EMPFOHLEN.
- ZULETZT ÜBERPRÜFEN SIE, DASS ALLE SCHRAUBEN FESTGEZOGEN WURDEN (SCHRAUBEN M6=9,6NM - SCHRAUBEN M8=23NM) UND DASS DIE DIEBSTAHLSICHERUNG UND DIE GUMMISTOPSEL AUF DER PLATTE KORREKT MONTIERT WURDEN.

ES

INSTRUCCIONES DE MONTAJE

- DESMONTAR EL SOPORTE DE LA MATRICULA ORIGINAL DEL SCOOTER, DESPLAZAR EL PEQUEÑO CHASIS Y REMPLAZARLO POR EL SOPORTE "4" (VER IMAGENES "A"-"B").
- VOLVER A MONTAR EL SOPORTE DE LA MATRICULA ORIGINAL COMO SE MUESTRA EN LAS IMÁGENES "B" Y "B1".
- MONTAR LOS SOPORTES "3" COMO SE MUESTRA EN LA IMAGEN "C", DESPUES DESMONTAR EL PEQUEÑO COLIN SUPERIOR Y COLOCAR LA PLANTILLA "HOJA N°3" PARA AGUJEREAR (AGUJEREAR ANTES CON UNA PUNTA PEQUENA, DESPUES AMPLIAR LOS AGUJEROS HASTA 18mm PARA COLOCAR LAS TRES GOMAS -REFERENCIA "17").
- MONTAR EL SOPORTE 2 COMO SE MUESTRA EN LA IMAGEN "D" Y DESPUES LA PARRILLA MONOKEY REALIZANDO EL MONTAJE COMO INDICA LA IMAGEN "E".
- TERMINAR EL MONTAJE COMPROBANDO QUE TODOS LOS TORNILLOS ESTEN BIEN APRETADOS (TORNILLOS M6=9,6Nm - TORNILLOS M8=23Nm) Y QUE LA TAPA ANTIRROBO Y LAS GOMAS ESTEN MONTADOS DE MANERA CORRECTA EN LA PARRILLA.