

# LS5144 - LS5144K

KIT SPECIFICO - SPECIFIC KIT - KIT SPECIFIQUE - SPEZIFISCHES KIT - KIT ESPECÍFICO - KIT ESPECÍFICA

	Descrizione/Description	Caratteristiche/Features	Codice/Code	Quantità/Quantity
1	Vite - Screw - Vis - Schraube Tornillo - Parafuso	TBEI M5x50	550TBEI	4
2	Rondella spaccata - Split washer Scheibe - Rondelle fendue Arandela seccionada - Arruela Dentada	Ø5mm	Z1049	4
3	Distanziale - Spacer Entretoise - Distanzstueck Distanciador - Espaçador	Foro 6,5mm / Esterno 14mm / Sp. 14mm	C14L14F6.5T	8
4	Componenti Originali - Original Parts Parties Originales - Original Bauteile Componentes Originales - Componentes Originais	-	-	-

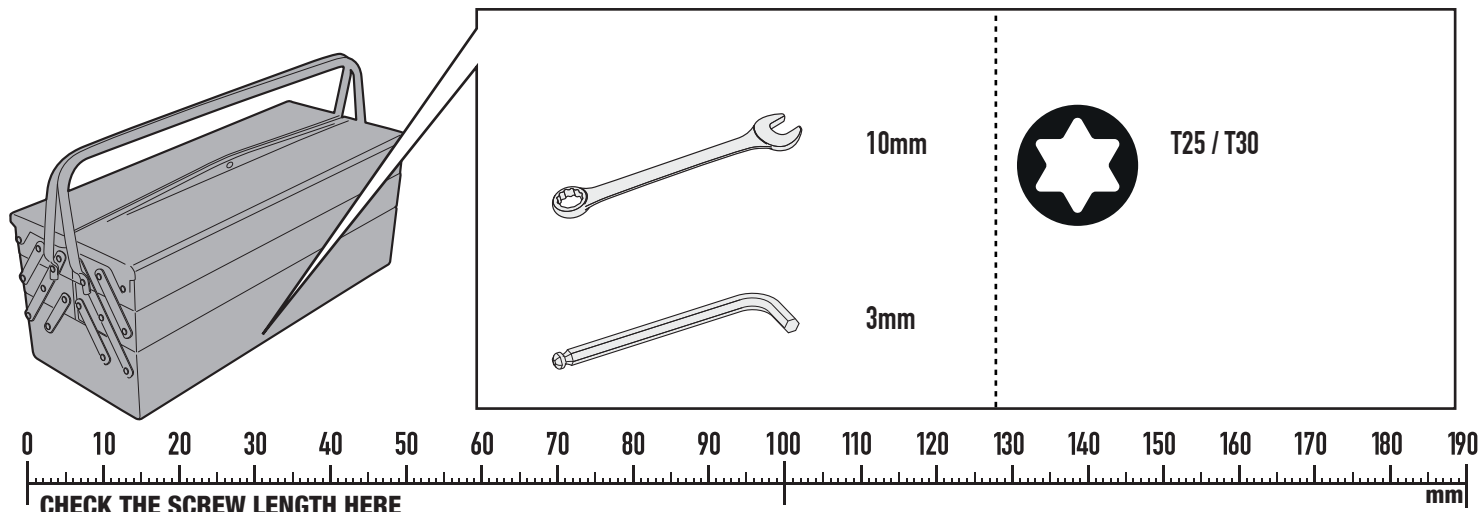
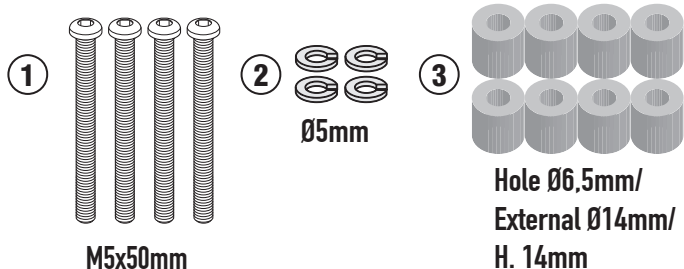

ISTRUZIONI DI MONTAGGIO - MOUNTING INSTRUCTIONS  
INSTRUCTIONS DE MONTAGE - BAUANLEITUNG  
INSTRUCCIONES DE MONTAJE - INSTRUÇÕES DE MONTAGEM

# LS5144 - LS5144K

KIT SPECIFICO - SPECIFIC KIT - KIT SPECIFIQUE - SPEZIFISCHES KIT - KIT ESPECÍFICO - KIT ESPECÍFICA

